

**OPERATOR'S, UNIT, DIRECT SUPPORT,
AND GENERAL SUPPORT
MAINTENANCE MANUAL**

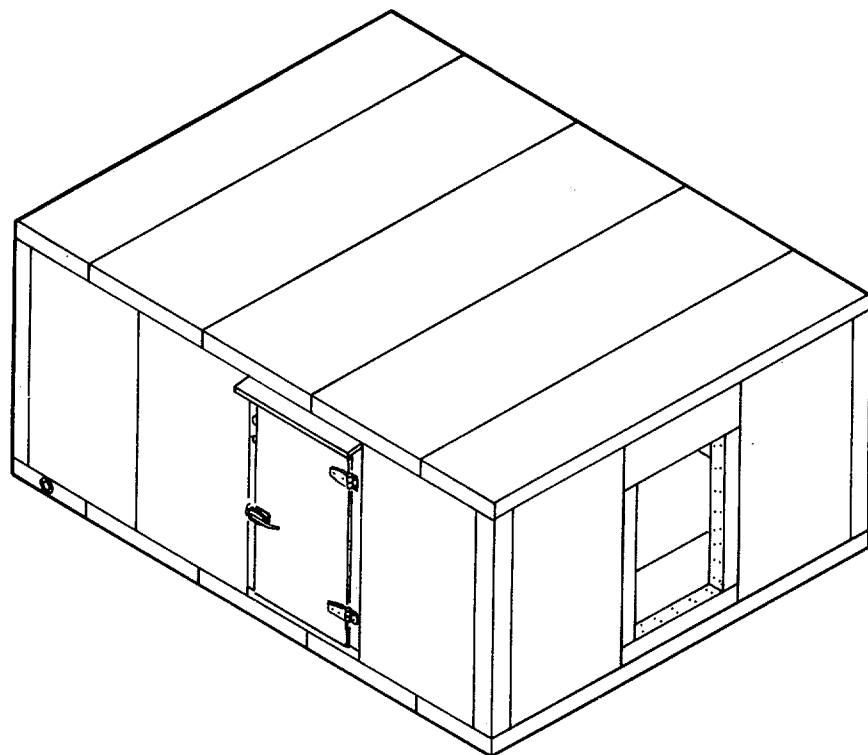

**REFRIGERATOR, PREFABRICATED,
(1200 CUBIC FOOT)
INSTRUCTIONS
MODEL TKR 1200C
NSN 4110-01-239-9200
AND
MODEL REF 1200
NSN 4110-01-315-9330**

Approved for public release: Distribution Is unlimited.

*This manual supersedes TM 5-4110-246-14, 29 June 1987, Including all changes

**TABLE OF
CONTENTS
PAGE i**

**INTRODUCTION
PAGE 1-1**

**OPERATOR
INSTRUCTIONS
PAGE 2-1**

**UNIT
MAINTENANCE
INSTRUCTIONS
PAGE 3-1**

**DIRECT
SUPPORT
AND GENERAL
SUPPORT
MAINTENANCE
INSTRUCTIONS
PAGE 4-1**

**APPENDICES
PAGE A-1**

**SUBJECT
INDEX
PAGE INDEX-1**

WARNING

HIGH VOLTAGE

is used in the operation of this equipment

DEATH ON CONTACT

may result if personnel fail to observe safety precautions

Never work on electronic equipment unless there is another person nearby who is familiar with the operation and hazards of the equipment and who is competent in administering first aid. When the technician is aided by operators, he must warn them about dangerous areas.

Whenever possible, the power supply to the equipment must be shut off before beginning work on the equipment. Take particular care to ground every capacitor likely to hold a dangerous potential. When working inside the equipment, after the power has been turned off, always ground every part before touching it.

Be careful not to contact high-voltage connections of 115V ac input connections when installing or operating this equipment.

Whenever the nature of the operation permits, keep one hand away from the equipment to reduce the hazard of current flowing through vital organs of the body.

WARNING Do not be misled by the term "low voltage" . Potentials as low as 50 volts may cause death under adverse conditions.

For Artificial Respiration, refer to FM 21-11.

a/(b blank)

CHANGE
NO. 1

HEADQUARTERS
DEPARTMENT OF THE ARMY
WASHINGTON, DC, 30 SEPTEMBER 2005

TECHNICAL MANUAL
OPERATOR'S, UNIT, DIRECT SUPPORT AND GENERAL SUPPORT
MAINTENANCE MANUAL

FOR
REFRIGERATOR, PREFABRICATED
(1200 CUBIC FOOT)

MODEL TKR 1200C NSN: 4110-01-239-9200
MODEL REF 1200 NSN: 4110-01-315-9330

DISTRIBUTION STATEMENT A: Approved for public release; distribution is unlimited.

TM 9-4110-246-14, 1 July 1992, is changes as follows:

1. File this sheet in the front of the manual for reference.
2. This change implements Army Maintenance Transformation and changes the Maintenance Allocation Chart (MAC) to support Field and Sustainment Maintenance.
3. New or updated text is indicated by a vertical bar in the outer margin.
4. Added illustrations are indicated by a vertical bar adjacent to the figure number. Changed illustrations are indicated by a miniature hand adjacent to the updated area and a vertical bar adjacent to the figure number.
5. Remove old pages and insert new pages as indicated below:

Remove Pages

B-1 – B-13/(B-14 blank)

2028

Insert Pages

A/(B blank)

B-1 – B-9/(B-10 blank)

Electronic 2028 Instructions/blank

Sample 2028 – Front/Back

2028 – Front/Back

2028 – Front/Back

2028 – Front/Back

TM 9-4110-246-14
TO 40R7-5-10-1
C1

By Order of the Secretaries of the Army, and Air Force:

PETER J. SCHOOMAKER
General, United States Army
Chief of Staff

Official:



*Administrative Assistant to the
Secretary of the Army*
0525504

MICHAEL E. RYAN
GENERAL, USAF
Chief of Staff

Official:

GEORGE T. BABBETT
General, USAF
Commander, Air Force Materiel Command

DISTRIBUTION:

To be distributed in accordance with initial distribution IDN 255795, requirements for TM 9-4110-246-14.

INSERT LATEST CHANGED PAGES. DESTROY SUPERSEDED PAGES.

LIST OF EFFECTIVE PAGES

NOTE: The portion of text affected by the change is indicated by a vertical line in the outer margins of the page. Changes to illustrations are indicated by shaded or screened areas, or by miniature pointing hands. Zero in the "Change No." column indicates an original page.

Dates of issue for original and changed pages are:

Original .. 0 .. 1 July 1992

Change .. 1 .. 30 September 2005

TOTAL NUMBER OF PAGES IN THIS PUBLICATION IS 120, CONSISTING OF THE FOLLOWING:

Page No.	Change No.	Page No.	Change No.
Title	0	A-1/(A-2 blank)	0
a/(b blank)	0	B-1 - B-9/(B-10 blank)	1
i - ii	0	C-1 - C-2	0
1-0 - 1-3/(1-4 blank)	0	D-1/(D-2 blank)	0
2-1 - 2-16	0	E-1 - E-2	0
3-1 - 3-55/(3-56 blank)	0	Index-1 - Index-2	0
4-1 - 4-2	0	Back Cover	0

TECHNICAL MANUAL

NO . 9-4110-246-14

HEADQUARTERS,
DEPARTMENTS OF THE ARMY AND AIR FORCE
WASHINGTON, D.C., 1 JULY 1992

**OPERATOR'S, UNIT, DIRECT SUPPORT AND GENERAL SUPPORT
MAINTENANCE MANUAL**

**REFRIGERATOR, PREFABRICATED,
(1200 CUBIC FOOT)
MODEL TKR 1200C
NSN 4110-01-239-9200
and
MODEL REF 1200
NSN 4110-01-315-9330**

REPORTING ERRORS AND RECOMMENDING IMPROVEMENTS

You can help Improve this manual. If you find any mistakes or if you know of a way to improve the procedures, please let us know. Mail your letter, DA Form 2028 (Recommended Changes to Publication and Blank Forms), or DA Form 2028-2 located in the back of this manual directly to: US Army Troop Support Command, ATTN AMSTR-MMTS, 4300 Goodfellow Blvd., St. Louis, MO 63120-1798. A reply will be furnished to you.

For Air Force, submit AFTO Form 22 (Technical Order System Publication Improvement Report and Reply) and forward to the address prescribed above for the Army. An Information copy of the prepared AFTO Form 22 shall be furnished to SA-ALC/MMDDA, Kelly AFB, TX 78241-5000.

Approved for public release; distribution is unlimited

Table of Contents

	Page
Chapter 1. INTRODUCTION	1-1
Section I. General Information	1-1
Section II. Equipment Description and Data	1-2
Section III. Technical Principles of Operation	1-3
Chapter 2. OPERATOR INSTRUCTIONS	2-1
Section I. Description and Use of Operator's Controls and Indicators	2-1
Section II. Preventive Maintenance Checks and Services (PMCS)	2-2
Section III. Operation Under Usual Conditions	2-16
Section IV. Operation Under Unusual Conditions	2-16
Chapter 3. UNIT MAINTENANCE INSTRUCTIONS.	3-1
Section I. Lubrication Instructions	3-1
Section II. Repair Parts, Special Tools, TMDE, and Support Equipment	3-1
Section III. Service Upon Receipt of Equipment	3-2
Section IV. Preventive Maintenance Checks and Services(PMCS)	3-11
Section V. Troubleshooting	3-12
Section VI. Unit Maintenance Procedures	3-17
Section VII. Preparation for Storage or Shipment	3-51

*This manual supersedes TM 5-4110-246-14, 29 June 1987, including all changes

Chapter 4.	DIRECT SUPPORT, AND GENERAL SUPPORT MAINTENANCE INSTRUCTIONS	4-1
Section I.	Troubleshooting	4-1
Section II.	Direct Support and General Support Maintenance Procedures	4-2
Appendix A.	REFERENCES	A-1
Appendix B.	MAINTENANCE ALLOCATION CHART	B-1
Section I.	Introduction	B-1
Section II.	Maintenance Allocation Chart	B-5
Section III.	Tools and Test Equipment Requirements.....	B-12
Section IV.	Remarks	B-13
Appendix C.	COMPONENTS OF END ITEM AND BASIC ISSUE ITEMS LIST	C-1
Appendix D.	ADDITIONAL AUTHORIZATION LIST	D-1
Appendix E.	EXPENDABLE/DURABLE SUPPLIES AND MATERIALS LIST	E-1
	SUBJECT INDEX.....	INDEX-1

**CHAPTER 1
INTRODUCTION
Section I . GENERAL INFORMATION**

1-1. SCOPE.

TYPE OF MANUAL:

Operator's, Unit, Direct Support, and General Support Maintenance Manual.

MODEL NUMBER AND EQUIPMENT NAME:

REF 1200 and TKR 1200C Refrigerator, Prefabricated (1200 cubic foot)

PURPOSE OF EQUIPMENT:

This unit is a field refrigerator box supplied without refrigeration equipment . Mechanical refrigeration equipment can be installed to provide cold storage for perishable items.

1-2. MAINTENANCE FORMS AND RECORDS.

Department of the Army forms and procedures used for equipment maintenance will be those prescribed by DA Pam 738-750, The Army Maintenance Management System (TAMMS).

1-3. DESTRUCTION OF ARMY MATERIAL TO PREVENT ENEMY USE.

Refer to TM 750-244-3 for procedures covering the destruction of Army materiel to prevent enemy use.

1-4. REPORTING EQUIPMENT IMPROVEMENT RECOMMENDATIONS (EIR'S).

If your refrigerator needs improvement, let us know . Send us an EIR . You, the user, are the only one who can tell us what you don't like about your equipment . Let us know why you don't like the design or performance. Put it on an SF 368 (Quality Deficiency Report) . Mail it to us at: Commander, US Army Troop Support Command, ATTN: AMSTR-MOF, 4300 Goodfellow Boulevard, St., Louis, MO 63120-1798.

1-5. EQUIPMENT CHARACTERISTICS, CAPABILITIES, AND FEATURES.
Section II . EQUIPMENT DESCRIPTION AND DATA

CHARACTERISTICS:

The 1200 cubic foot prefabricated refrigerator is a single compartment unit supplied without refrigeration machinery . The unit consists of a roof/ceiling section, a wall/corner support section, and a floor section, all assembled from interlocking, individually insulated and prefabricated panels.

The wall/corner support section consists of standard wall panels, four corner panels, a door frame panel with a walk-in door, and two evaporator panels into which refrigeration equipment can be installed. The standard wall panels, evaporator panel, and door frame panel are interchangeable to allow any desired arrangement for easy access and optimized refrigeration equipment mounting.

CAPABILITIES AND FEATURES:

The refrigerator is provided with an external power receptacle, inside light and switch, and an outside pilot light . An internally-mounted thermometer which displays the inside temperature is also supplied. The hinged refrigerator door is equipped with a safety latch handle with a padlock and chain for securing the latch handle . The pilot light indicates when the inside light is on.

1-6. LOCATION AND DESCRIPTION OF MAJOR COMPONENTS.

CEILING PANEL ASSEMBLY (1, typical) . Provides roof insulation for refrigerator unit . Ceiling structure consists of left ceiling panel assembly, right ceiling panel assembly, and three center ceiling panel assemblies.

CORNER PANEL ASSEMBLY (2, typical) . Provides corner structural support and insulation for unit . Refrigerator has four corner panel assemblies that are part of the wall structure.

STANDARD WALL PANEL ASSEMBLY (3, typical) . Provides side structural support and insulation for refrigerator unit . Refrigerator has eleven standard wall panel assemblies.

EVAPORATOR PANEL ASSEMBLY (4, typical) . Part of refrigerator wall structure that allows mounting of refrigeration cooling equipment (not supplied) . Unit has two evaporator panel assemblies.

FLOOR PANEL ASSEMBLY (5, typical) . Provides base structural support and insulation for unit . Floor structure consists of left floor panel assembly, three center floor panel assemblies and right floor panel assemblies.

DOOR FRAME PANEL ASSEMBLY (6) . Provides mounting for refrigerator walk-in door and contains refrigerator electrical wiring and components.

WALK-IN DOOR ASSEMBLY (7) . Provides access to and from refrigerator unit.

1-7. EQUIPMENT DATA.

Length	16 feet, 7 inches (5055 mm)
Width	12 feet, 9 5/8 inches (3903 mm)
Height	7 feet, 5 3/4 inches (2280 mm)
Capacity (Volume)	1900 cubic feet (53.80 cu.m)
Electrical Requirements	125V ac, 50/60 Hz (interior vapor proof light and exterior pilot light)
Weight	4,140 lbs (9,108 Kgs)

Section III . TECHNICAL PRINCIPLES OF OPERATION

1-8. The ceiling, wall, and floor panel assemblies are wooden-framed, filled with densely-packed insulating foam, and covered with sheet metal . This provides an insulating barrier which helps maintain temperatures inside the refrigerator . Gasket panels are used between the interlocking refrigerator panels to seal the unit.

A thermometer mounted inside displays the refrigerator's inside temperature.

The external power receptacle is connected to the light switch, vapor proof light, and pilot light . The switch is mounted inside and controls the inside vapor proof light . The pilot light is outside and indicates when the inside vapor proof light is on . This circuit requires a 125V ac input to power the lights.

CHAPTER 2

OPERATOR INSTRUCTIONS

Section I . DESCRIPTION AND USE OF OPERATOR'S CONTROLS AND INDICATORS

2-1 . CONTROLS AND INDICATORS.

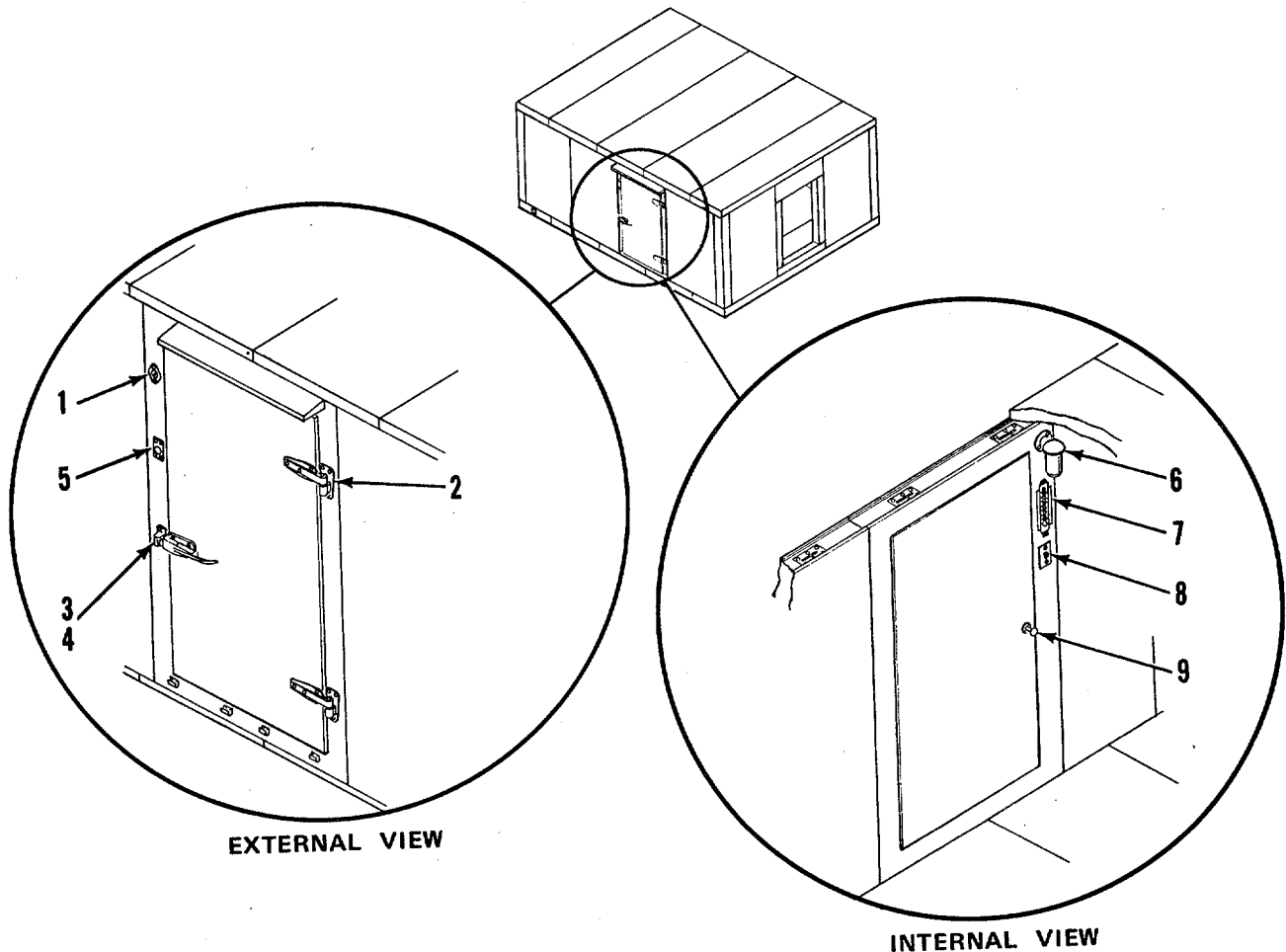

KEY	CONTROLS OR INDICATOR	FUNCTION
1	Power Receptacle	Used to connect 125V ac input to inside vapor proof and outside pilot lights. Mounts door to unit and allows opening and closing of the door. Provides outside handle for opening and closing door, latches to secure door in closed position . Supplied with pushrod used to open door from inside.
2	Hinge	
3	Safety Latch	

KEY	CONTROLS OR INDICATOR	FUNCTION
4	Padlock and Chain	Provides means of positively locking unit to prevent theft.
5	Pilot Light	Lights to indicate when inside vapor proof light is on.
6	Vapor Proof Light	Provides internal lighting for refrigerator.
7	Thermometer	Displays inside temperature.
8	Switch	Turns vapor proof light on or off . Pilot light will also turn on.
9	Safety Latch Pushrod	Provides means of unlatching door from the inside.

Section II . PREVENTIVE MAINTENANCE CHECKS AND SERVICES(PMCS)

2-2 . GENERAL.

- Before you operate . Always keep in mind the CAUTIONS and WARNINGS . Perform your before (B) PMCS .
- While you operate . Always keep in mind the CAUTIONS and WARNINGS . Perform your during (D) PMCS.
- Each week . Be sure to perform your weekly (W) PMCS.
- Once a month . Be sure to perform your monthly (M) PMCS.
- If your equipment fails to operate . Troubleshoot with proper equipment. Report any deficiencies using the proper forms . See DA Pam 738-750 The Army Maintenance Management System (TAMMS).
- Why perform PMCS? PMCS check procedures are to see that the unit is working properly . PMCS service procedures are to help keep the unit working properly.
- When to perform PMCS? PMCS procedures shall be performed at the times indicated in the INTERNAL column of the PMCS table . The PMCS intervals are before operation (B), during operation (D), weekly (W), and monthly (M) . The item numbers indicate the sequence of procedures to be performed.
- Equipment is Not Ready/Available If . Guidelines which identify the refrigerator as "not ready/available" for use appear in the EQUIPMENT IS NOT READY/AVAILABLE IF column of the table . If the refrigerator is identified as not ready for use, the problem must be corrected before the unit can be used.

- Reporting Deficiencies . Report any deficiencies found during PMCS. Department of the Army forms and procedures used for equipment maintenance will be those prescribed by DA Pam 738-750, (TAMMS).

WARNING

Disconnect power cord from unit, and power cord from power supply before performing your PMCS.

NOTE

If the equipment must be kept in continuous operation, check and service only those items that can be checked and serviced without disturbing operation . Make the complete checks and services when the equipment can be shut down.

Perform weekly (W) as well as before operation (B) PMCS if:

- You are the assigned operator and have not operated the item since the last weekly PMCS.
- You are operating the item for the first time.

Item numbers which appear on this table are to be used in the "TM Number" column on DA Form 2404, Equipment Inspection and Maintenance Worksheet in recording the results of the PMCS.

OPERATOR/CREW PREVENTIVE MAINTENANCE CHECKS AND SERVICES

B—BEFORE OPERATION

D—DURING OPERATION

W—WEEKLY

M—MONTHLY

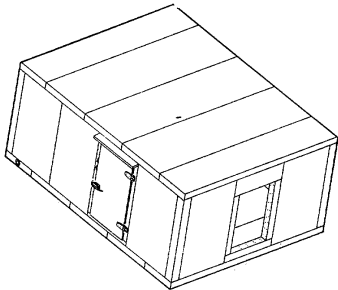
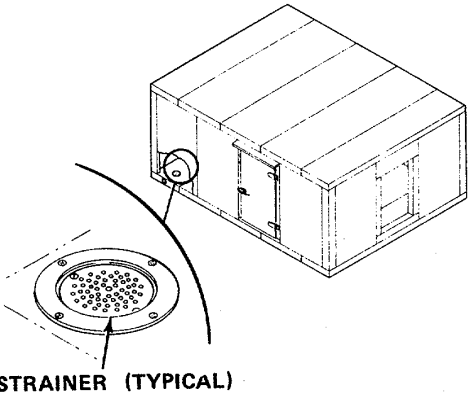
ITEM NO.	INTERVAL					ITEM TO BE INSPECTED PROCEDURE	EQUIPMENT IS NOT READY/AVAILABLE IF:
	B	D	A	W	M		
1	•					<p>Refrigerator Panel Assemblies and Door Assembly . Visually inspect all refrigerator panel assemblies and door assembly for cracking or visible holes.</p> 	Any holes or cracks on panel assemblies are visible.
2					•	<p>Refrigerator Panel Assemblies and Door Assembly . Wash interior with baking soda (item 2, Appx E) and water . Rinse and dry thoroughly.</p>	Strainers are damaged.
3					•	<p>Floor Strainers . Check strainers for accumulated dirt, clogging, and damage.</p>  <p>STRAINER (TYPICAL)</p>	

OPERATOR/CREW PREVENTIVE MAINTENANCE CHECKS AND SERVICES

B—BEFORE OPERATION

D—DURING OPERATION

W—WEEKLY

M—MONTHLY

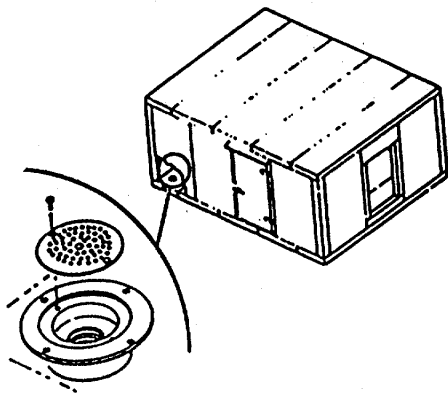
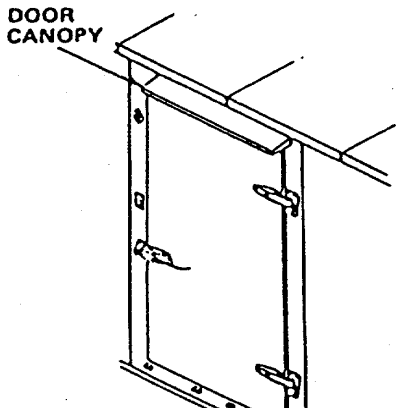
ITEM NO.	INTERVAL					ITEM TO BE INSPECTED PROCEDURE: CHECK FOR AND HAVE REPAIRED, FILLED, OR ADJUSTED AS NEEDED	EQUIPMENT IS NOT READY/AVAILABLE IF:
	B	D	A	W	M		
4				•		<p>Floor Strainers . Remove floor strainers by removing screws. Clean with wire brush to remove accumulated dirt or debris.</p>  <p>TYPICAL: 2 PLACES</p>	Strainers are clogged.
5					•	<p>Outside Drains . Inspect outside drains for clogging or dirt accumulations . Clean with bristle brush to remove accumulated dirt or debris.</p>	Outside drains are clogged.
6	•					<p>Door Canopy . Check roof canopy for holes, punctures, or tears.</p> 	

OPERATOR/CREW PREVENTIVE MAINTENANCE CHECKS AND SERVICES

B—BEFORE OPERATION

D—DURING OPERATION

W—WEEKLY

M—MONTHLY

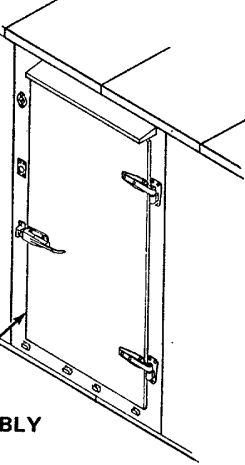
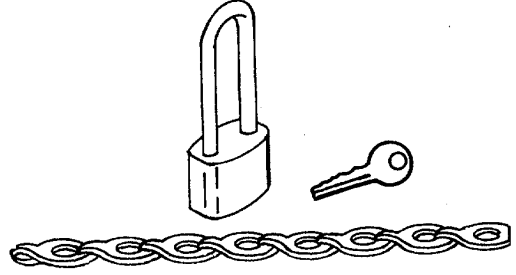
ITEM NO.	INTERVAL					ITEM TO BE INSPECTED PROCEDURE: CHECK FOR AND HAVE REPAIRED, FILLED, OR ADJUSTED AS NEEDED	EQUIPMENT IS NOT READY/AVAILABLE IF:
	B	D	A	W	M		
7	•					<p>Walk-in Door Assembly. Check for proper mounting. Door must open and close easily, and latch shall close with its strike.</p>  <p>WALK-IN DOOR ASSEMBLY</p>	Door fails to open properly.
8	•					<p>Padlock and Chain . Inspect padlock for cracks, breaks, and operability using key . Check chain for distorted or damaged links . Undamaged portion of chain must be long enough to secure door.</p> 	

OPERATOR/CREW PREVENTIVE MAINTENANCE CHECKS AND SERVICES

B—BEFORE OPERATION

D—DURING OPERATION

W—WEEKLY

M—MONTHLY

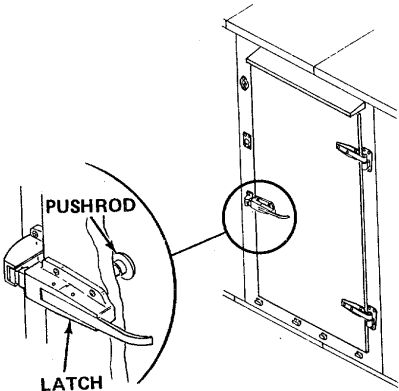
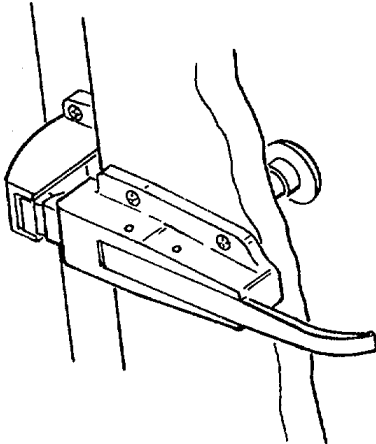
ITEM NO.	INTERVAL					ITEM TO BE INSPECTED PROCEDURE: CHECK FOR AND HAVE REPAIRED, FILLED, OR ADJUSTED AS NEEDED	EQUIPMENT IS NOT READY/AVAILABLE IF:
	B	D	A	W	M		
9	•					<p>Latch and Strike Assembly. Check for cracks, breaks, excessive wear, and loose or missing hardware . Operate internal pushrod to ensure it opens latch.</p> 	<p>Latch is damaged, mounting hardware is loose or missing, or pushrod fails to open latch.</p>
10	•					<p>Latch . Lubricate with low viscosity SAE oil (item 5, Appx E) once a month.</p> 	<p>Latch sticks.</p>

OPERATOR/CREW PREVENTIVE MAINTENANCE CHECKS AND SERVICES

B—BEFORE OPERATION

D—DURING OPERATION

W—WEEKLY

M—MONTHLY

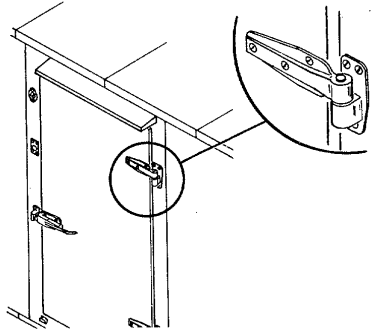
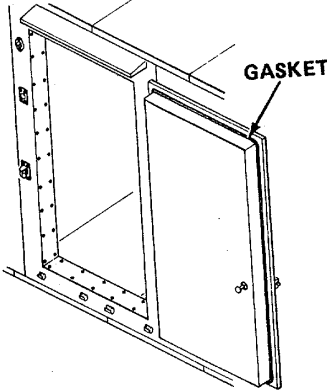
ITEM NO.	INTERVAL					ITEM TO BE INSPECTED PROCEDURE: CHECK FOR AND HAVE REPAIRED, FILLED, OR ADJUSTED AS NEEDED	EQUIPMENT IS NOT READY/AVAILABLE IF:
	B	D	A	W	M		
11	•					<p>Hinges . Check for cracks, breaks, excessive wear, and loose or missing hardware . Open and close door to be sure hinges work.</p> 	Hinge is damaged, insecurely mounted or binds.
12					•	<p>Hinges . Lubricate with low viscosity SAE oil (item 5, Appx E) once a month.</p>	Hinges stick.
13					•	<p>Door Gasket . With inside vapor proof light switched on, close door . There shall be no light visible around door . Visually check gasket for tears, loose mounting, wear, or aging.</p> 	Gasket is worn or damaged.

OPERATOR/CREW PREVENTIVE MAINTENANCE CHECKS AND SERVICES

B—BEFORE OPERATION

D—DURING OPERATION

W—WEEKLY

M—MONTHLY

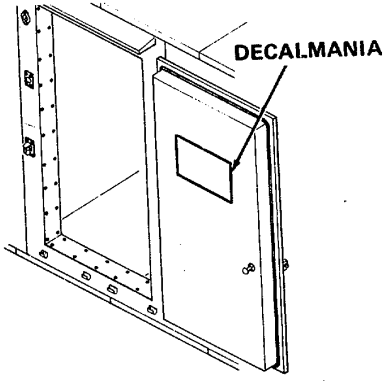
ITEM NO.	INTERVAL					ITEM TO BE INSPECTED PROCEDURE: CHECK FOR AND HAVE REPAIRED, FILLED, OR ADJUSTED AS NEEDED	EQUIPMENT IS NOT READY/AVAILABLE IF:
	B	D	A	W	M		
14					•	<p>Decalmania . Inspect decalmania for damage and legibility.</p>  <p>Replace decalmania if damaged or illegible.</p> <p>WARNING</p> <p>The female receptacle is used to connect 125V ac to the refrigerator . Disconnect the wire from the power source or shut off power at source before inspecting the plug.</p>	

OPERATOR/CREW PREVENTIVE MAINTENANCE CHECKS AND SERVICES

B—BEFORE OPERATION

D—DURING OPERATION

W—WEEKLY

M—MONTHLY

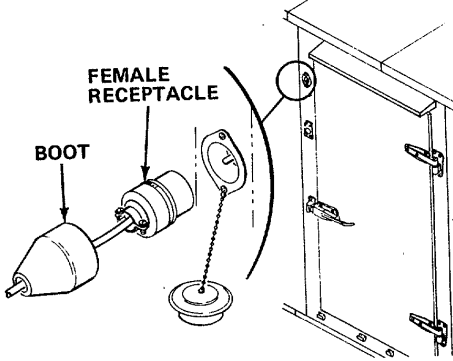
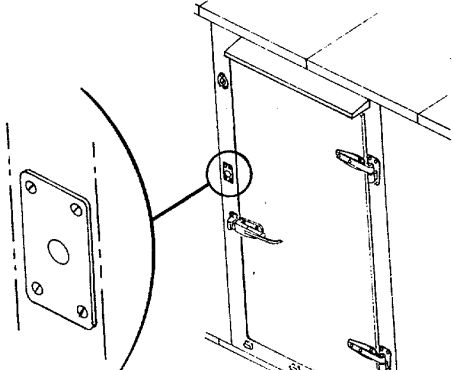
ITEM NO.	INTERVAL					ITEM TO BE INSPECTED PROCEDURE: CHECK FOR AND HAVE REPAIRED, FILLED, OR ADJUSTED AS NEEDED	EQUIPMENT IS NOT READY/AVAILABLE IF:
	B	D	A	W	M		
15						 <p>Female Receptacle . Inspect receptacle for cracks, breaks, and terminals for signs of scorching or shorts . Pull boot from receptacle and check for secure installation of power supply cord.</p>	Receptacle is damaged or signs of scorching is evident.
16						<p>Boot . Visually inspect for cracks, signs of scorching, damage, or deterioration.</p>	Boot is damaged.
17	•					<p>Pilot Light Cover . Check for cracks, breaks, and loose or missing hardware.</p> 	

OPERATOR/CREW PREVENTIVE MAINTENANCE CHECKS AND SERVICES

B—BEFORE OPERATION

D—DURING OPERATION

W—WEEKLY

M—MONTHLY

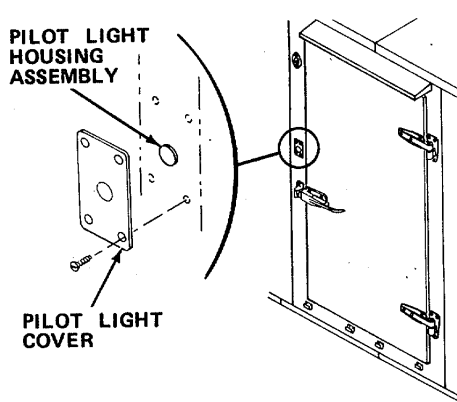
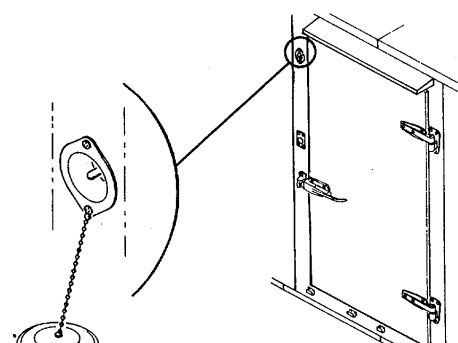
ITEM NO.	INTERVAL					ITEM TO BE INSPECTED PROCEDURE: CHECK FOR AND HAVE REPAIRED, FILLED, OR ADJUSTED AS NEEDED	EQUIPMENT IS NOT READY/AVAILABLE IF:
	B	D	A	W	M		
18				•		<p>Pilot Light Housing Assembly. Remove screws to remove pilot light cover . Inspect pilot light housing assembly for cracks, breaks, signs of scorching, and dirt accumulation . Clean with brush to remove dirt.</p> 	<p>Pilot light housing assembly is damaged or signs of scorching is evident.</p>
19	•					<p>Male Receptacle, Cap and Chain. Check for missing cap and chain . Unplug cap and check male receptacle for dust and dirt accumulation, bent or damaged terminals, and signs of scorching or shorts.</p> 	<p>Cap and chain are missing; male receptacle terminals are damaged or signs of scorching and shorts are evident.</p>

OPERATOR/CREW PREVENTIVE MAINTENANCE CHECKS AND SERVICES

B—BEFORE OPERATION

D—DURING OPERATION

W—WEEKLY

M—MONTHLY

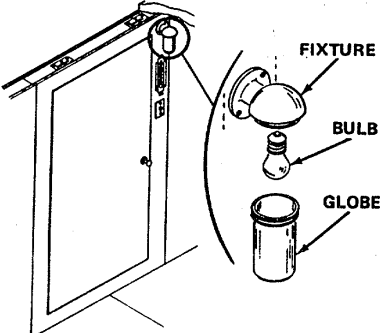
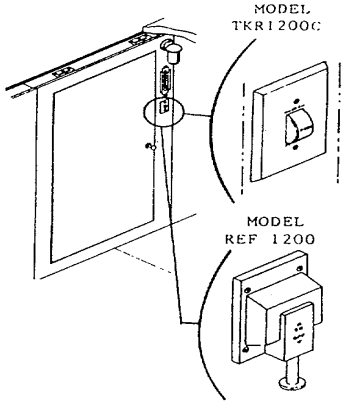
ITEM NO.	INTERVAL					ITEM TO BE INSPECTED PROCEDURE: CHECK FOR AND HAVE REPAIRED, FILLED, OR ADJUSTED AS NEEDED	EQUIPMENT IS NOT READY/AVAILABLE IF:
	B	D	A	W	M		
20	•					<p>Vapor Proof Light Fixture and Globe . Check fixture for secure mounting, missing hardware, and damage . Inspect globe for cracks, breaks, and damage</p> 	<p>Mounting hardware is missing, fixture is not securely mounted, globe is cracked or damaged</p>
21				•		<p>Vapor Proof Light Bulb and Socket . Unthread globe to expose bulb Inspect bulb for serviceability and signs of scorching</p>	<p>Bulb is unusable and socket shows signs of scorching</p>
22	•					<p>Switch Cover . Check for cracks or breaks</p> 	<p>Switch cover is damaged</p>

OPERATOR/CREW PREVENTIVE MAINTENANCE CHECKS AND SERVICES

B—BEFORE OPERATION

D—DURING OPERATION

W—WEEKLY

M—MONTHLY

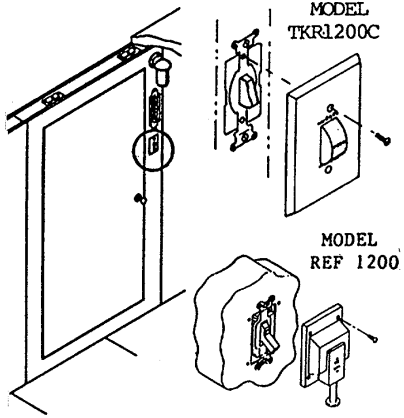
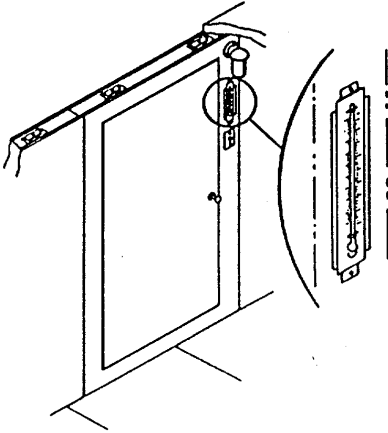
ITEM NO.	INTERVAL					ITEM TO BE INSPECTED PROCEDURE: CHECK FOR AND HAVE REPAIRED, FILLED, OR ADJUSTED AS NEEDED	EQUIPMENT IS NOT READY/AVAILABLE IF:
	B	D	A	W	M		
23					•	<p>Switch . Remove screws and remove switch cover to check switch . Check for cracking, scorching, or other damage.</p> 	Switch is damaged or signs of scorching is evident.
24	•					<p>Thermometer . Inspect thermometer for cracks, damage, secure mounting, missing hardware, and legibility of markings.</p> 	Thermometer is cracked or damaged or markings are illegible.

OPERATOR/CREW PREVENTIVE MAINTENANCE CHECKS AND SERVICES

B—BEFORE OPERATION

D—DURING OPERATION

W—WEEKLY

M—MONTHLY

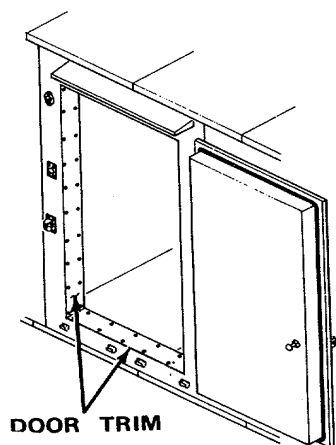
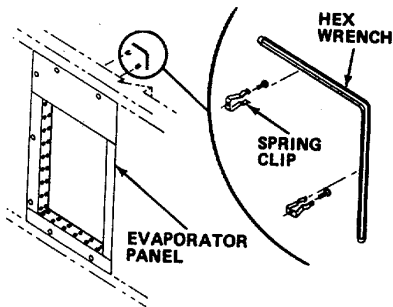
ITEM NO.	INTERVAL					ITEM TO BE INSPECTED PROCEDURE: CHECK FOR AND HAVE REPAIRED, FILLED, OR ADJUSTED AS NEEDED	EQUIPMENT IS NOT READY/AVAILABLE IF:
	B	D	A	W	M		
25		•				<p>Door Trim (Sill, Head, and Door Jambs) . Check for cracks, warps, deterioration, or damage.</p>  <p>DOOR TRIM</p>	Door trim is damaged or deteriorated.
26		•				<p>Spring Clip . Inspect spring clips on both evaporator panels for secure mounting, corrosion, or damage.</p>  <p>EVAPORATOR PANEL HEX WRENCH SPRING CLIP</p>	
27		•				<p>Hex Wrenches . Check for missing hex wrenches (4, total). Inspect hex wrenches for worn or stripped points.</p>	

OPERATOR/CREW PREVENTIVE MAINTENANCE CHECKS AND SERVICES

B—BEFORE OPERATION

D—DURING OPERATION

W—WEEKLY

M—MONTHLY

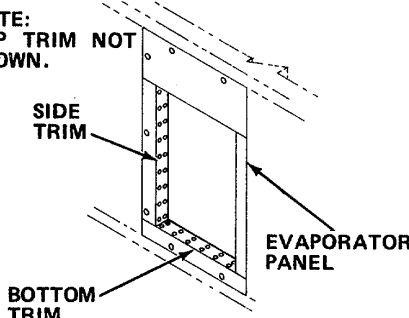
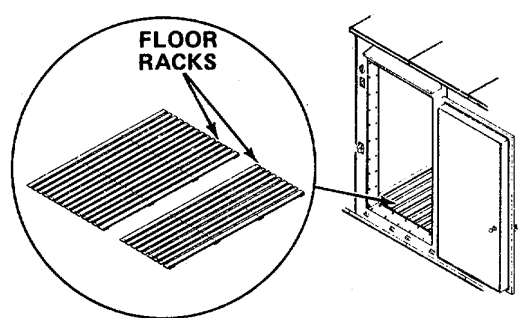
ITEM NO.	INTERVAL					ITEM TO BE INSPECTED PROCEDURE: CHECK FOR AND HAVE REPAIRED, FILLED, OR ADJUSTED AS NEEDED	EQUIPMENT IS NOT READY/AVAILABLE IF:
	B	D	A	W	M		
28	•					<p>Evaporator Panel Top, Bottom, and Side Trims . With refrigeration equipment removed, inspect top, bottom and side trims on both evaporator panels for warps, deterioration, or damage.</p> <p>NOTE: TOP TRIM NOT SHOWN.</p>  <p>The diagram shows a perspective view of an evaporator panel. It is a rectangular frame with a grid of small circles inside. Labels with arrows point to the 'SIDE TRIM' on the left edge, the 'BOTTOM TRIM' on the bottom edge, and the 'EVAPORATOR PANEL' in the center. A dashed line indicates the top trim, which is noted as not shown.</p>	Trims are warped, damaged, or deteriorated.
29					•	<p>Floor Racks . Inspect floor racks for deterioration, damage, or loose slots.</p>  <p>The diagram consists of two parts. On the left, a circular inset shows a close-up of 'FLOOR RACKS', which are several parallel, slightly curved metal strips. On the right, a perspective view shows these racks installed inside a rectangular panel frame.</p>	
30					•	<p>Floor Racks . Remove floor racks from refrigerator . Scrub with soap and water solution . Rinse and reinstall racks after scrubbing.</p>	

Section III . OPERATION UNDER USUAL CONDITIONS

2-3. ASSEMBLY AND PREPARATION FOR USE.

Refer to Instruction, paragraph 3-7, for refrigerator assembly and preparation for use.

2-4. OPERATING PROCEDURES.

In normal operation, mechanical refrigeration equipment will be used with this refrigerator . After installation, refer to the technical manual covering the cooling unit used in your refrigerator and operate the unit as instructed.

NOTE

Be sure door is closed securely when not in use to prevent heat from entering refrigerator.

Observe the thermometer regularly to be sure the temperature range established by your supervisor is maintained.

2-5. PREPARATION FOR MOVEMENT.

Refer to Unit Maintenance Instructions, paragraph 3-47, for refrigerator disassembly instructions and preparation for movement.

2-6. OPERATING INSTRUCTIONS ON DECALS AND INSTRUCTION PLATES.

Except for the installation instruction decal mounted on the walk-in door assembly, the refrigerator has no operating decals or plate mounted operating instructions . Refer to the technical manuals covering installed refrigeration equipment for locations of their respective operating decals and plates.

Section IV . OPERATION UNDER UNUSUAL CONDITIONS

2-7. OPERATION UNDER RAINY OR HUMID CONDITIONS.

If the refrigerator is installed outdoors, protect the hinges and latches by coating them with a waterproof substance, such as grease (item 4, Appx E) or corrosion preventive compound (item 3, Appx E) to prevent rust or corrosion. Use canvas or other waterproof material to protect the unit as much as possible in order to reduce the rusting and corrosion action.

2-8. OPERATION IN SALT-WATER AREAS.

- A. Wash the outside of the refrigerator with clean, fresh water, every other day if possible.
- B. Coat exposed surfaces with rust proof compound (item 8, Appx E).
- C. Remove any rust or corrosion immediately, apply rust arresting coating (item 7, Appx E).

CHAPTER 3

UNIT MAINTENANCE INSTRUCTIONS

Section I . LUBRICATION INSTRUCTIONS

- 3-1. The door hinges and latch are the only parts of the refrigerator which require lubrication . Use a low viscosity SAE oil (item 5, Appx E) on these parts once a month.

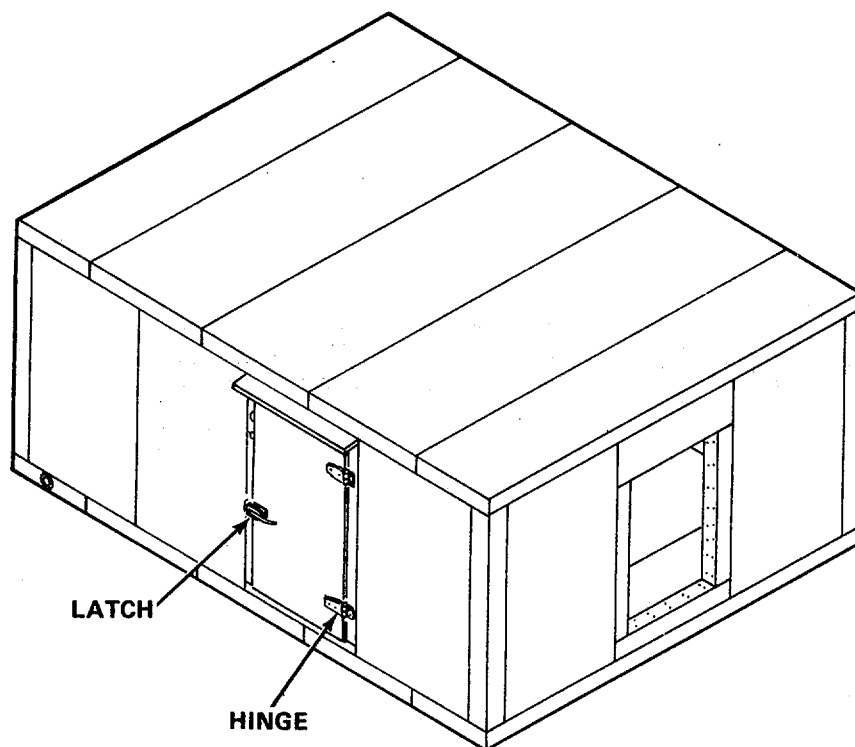

NOTE

THESE LUBRICATION INSTRUCTIONS ARE MANDATORY.

Section II . REPAIR PARTS, SPECIAL TOOLS, TMDE, AND SUPPORT EQUIPMENT

3-2. **COMMON TOOLS AND EQUIPMENT.**

For authorized common tools and equipment, refer to the Modified Table of Organization and Equipment (MTOE) applicable to your unit.

3-3. **SPECIAL TOOLS, TMDE, AND SUPPORT EQUIPMENT.**

Special Tools, TMDE (Test, Measurement, and Diagnostic Equipment) or support equipment required by organizational maintenance personnel for refrigerator maintenance are listed in TM 9-4110-246-24P.

3-4. **REPAIR PARTS.**

Repair parts are listed and illustrated in TM 9-4110-246-24P.

Section III . SERVICE UPON RECEIPT OF EQUIPMENT

3-5. SITE AND SHELTER REQUIREMENTS.

The refrigerator must be set up on a flat, level surface or platform capable of withstanding 250 pounds per square foot (1221 kg/sq.m.) . The area must be a minimum of 18 feet (5.5 m) front to back, and 14 feet (4.3 m) wide . If a mechanical refrigeration (cooling) unit is to be used, refer to the manual covering the unit to be used for additional space requirements . The - refrigerator is 7 feet, 5 3/4 inches (2280 mm) tall . A 125V ac power source is required for operation of the refrigerator lights.

3-6. SERVICE UPON RECEIPT OF EQUIPMENT.

A. Unloading.

1. The crated panels and components of the prefabricated refrigerators may be shipped either by tractor-trailer or rail . Remove all tie-down cables, strapping, blocking, and the like, which secure the crated or skid-mounted components to the bed of the carrier . Refer to the figure and remove all tie-downs and blocking.

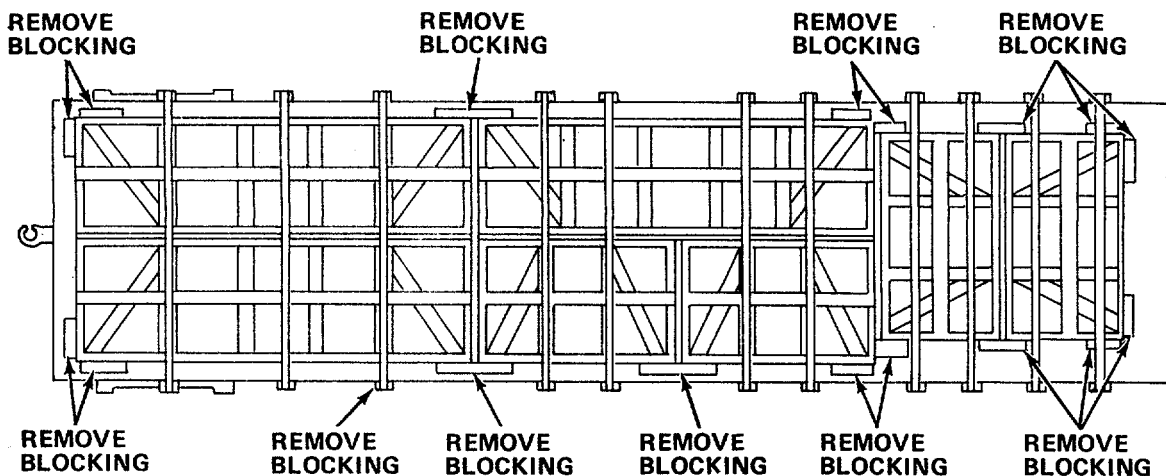

2. Use forklift or hoist capable of supporting 2,200 lbs (4840 Kgs), and remove the crated or skid-mounted components from the bed of the carrier.
3. Remove banding, carting, and blocking, being extremely careful not to damage the panels . If skid-mounted, cut the strapping and remove cushioning and spacers . Unpack separately packed components from the containers . Remove the tape from drains, lighting, switch, and power receptacle mounting holes.

B. Checking Unpacked Equipment.

1. Visually inspect all component parts of the prefabricated refrigerator for loss of parts or damage which may have occurred during shipment . If the equipment has been damaged, report the damage on DD Form 6, Packaging Improvement Report.

2. Check the equipment against the packing slip to see if the shipment is complete . Report all discrepancies in accordance with the instructions of DA Pam 738-750.
3. Tighten all loose mounting hardware and replace damaged or missing parts. Inspect for clogged drain strainers . Make certain all camlocks are in proper working condition . Check gasket panels on all panel assemblies for damage, deterioration, or loose mounting.
4. Before placing any panel assembly in position, make certain all camlocks rotate freely and are rotated fully counterclockwise . Remove all foreign material from camlock recesses and make sure hooks are not damaged or bent . Lubricate as necessary.

3-7. INSTALLATION INSTRUCTIONS.

A. TOOLS, TEST EQUIPMENT, AND MATERIALS REQUIRED FOR INSTALLATION.

- Hex Wrench
- Screwdriver, Cross Tip
- Screwdriver, Flat Tip
- Pocket Knife
- Four-Inch Tape (item 11, Appx E)

B. PERSONAL REQUIRED . 4.

C. ASSEMBLY OF EQUIPMENT.

CAUTION

Before positioning any panel, be sure camlocks are rotated fully counterclockwise (retracted) to prevent damage to locking mechanisms . Exercise caution when positioning panels to avoid damaging the gaskets.

NOTE

When positioning refrigerator panels, be sure camlock sides (without gaskets) are set up properly against mating eyelet side (with gaskets) of the adjacent panel . Once positioned, panels are locked together by rotating camlocks fully clockwise using hex wrench.

1. Preparation of site: The area where refrigerator is to be erected should be level to prevent misalignment of floor panels . For proper ventilation of underneath surface of floor panels, a completely level and structurally sound sub-base (to support the entire refrigerator) should be built on the site from requisitioned dunnage and/or crating lumber.

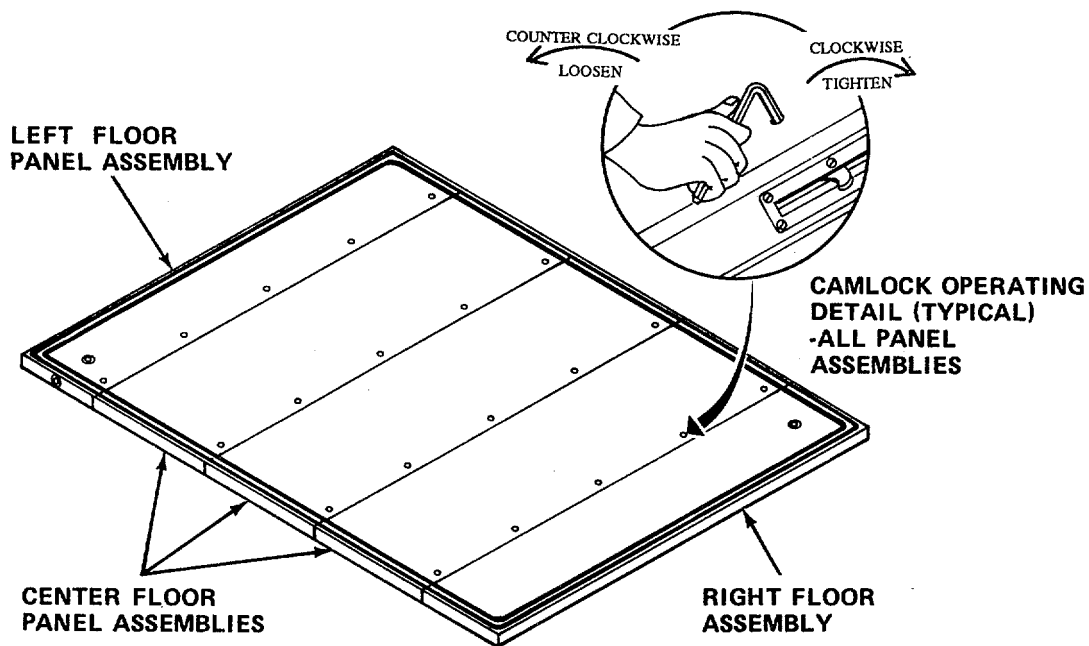

2. Position right, center, and left floor panel assemblies, gasket sides up on prepared level surface or platform. Lock floor panel assemblies together by rotating camlocks fully clockwise using the hex wrench.

3. Position any corner panel assembly over right or left floor panel assembly. Place a standard wall panel assembly on each side of the corner panel and lock all three panels in together before proceeding. Starting at this corner, continue installing standard wall panel, evaporator panel, door frame panel, and corner panel assemblies until point of beginning is reached. Lock any wall structure panel assembly to adjacent panel assembly once it is positioned. Do not lock any wall structure panel assembly to any floor panel assembly until entire wall structure is erected and locked together.

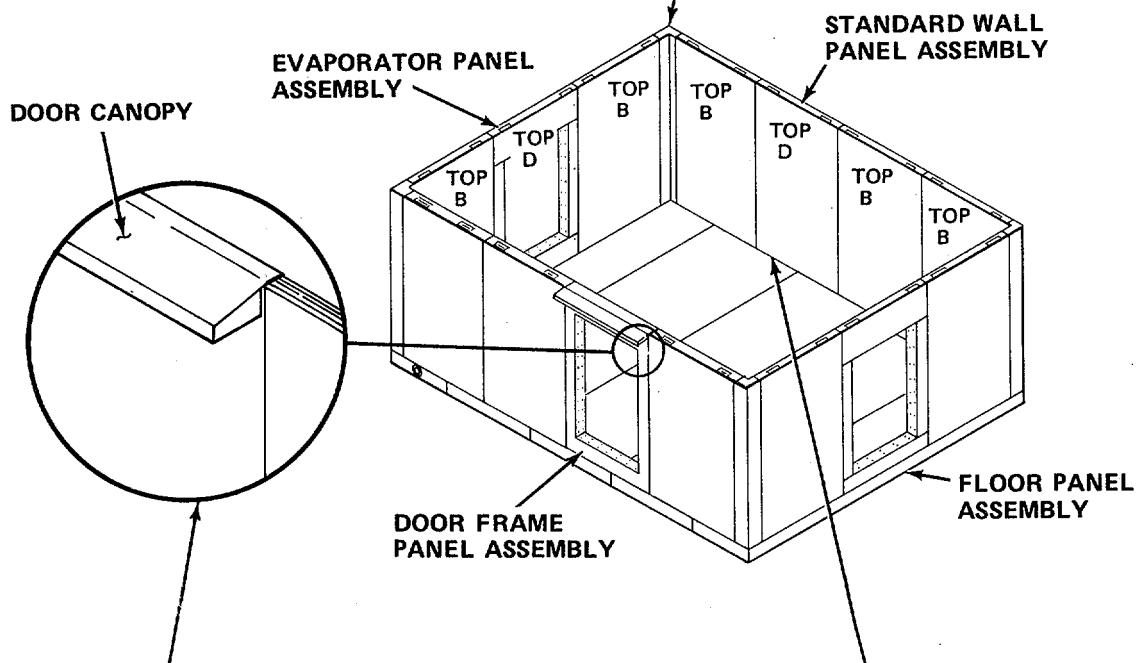

5. Hang door canopy over lip on door frame panel assembly.

4. Once entire wall structure is erected and locked together, lock wall structure panels to floor panel assemblies. Begin with one panel and continue around refrigerator until point of beginning is reached.

NOTE

The door frame panel, evaporator panel, and standard wall panel assemblies are interchangeable and may be arranged as desired. Prior to installing, determine proper wall structure arrangement for convenient access during operation and refrigeration equipment servicing.

6. Position right ceiling panel, three center ceiling panels, and left ceiling panel assemblies gasket side down over top ends of wall structure panel assemblies. Lock each ceiling panel assembly to adjacent ceiling panel assembly as soon as it is positioned. Do not lock any wall structure panel assembly to any ceiling panel assembly until all ceiling panel assemblies are installed and locked together.

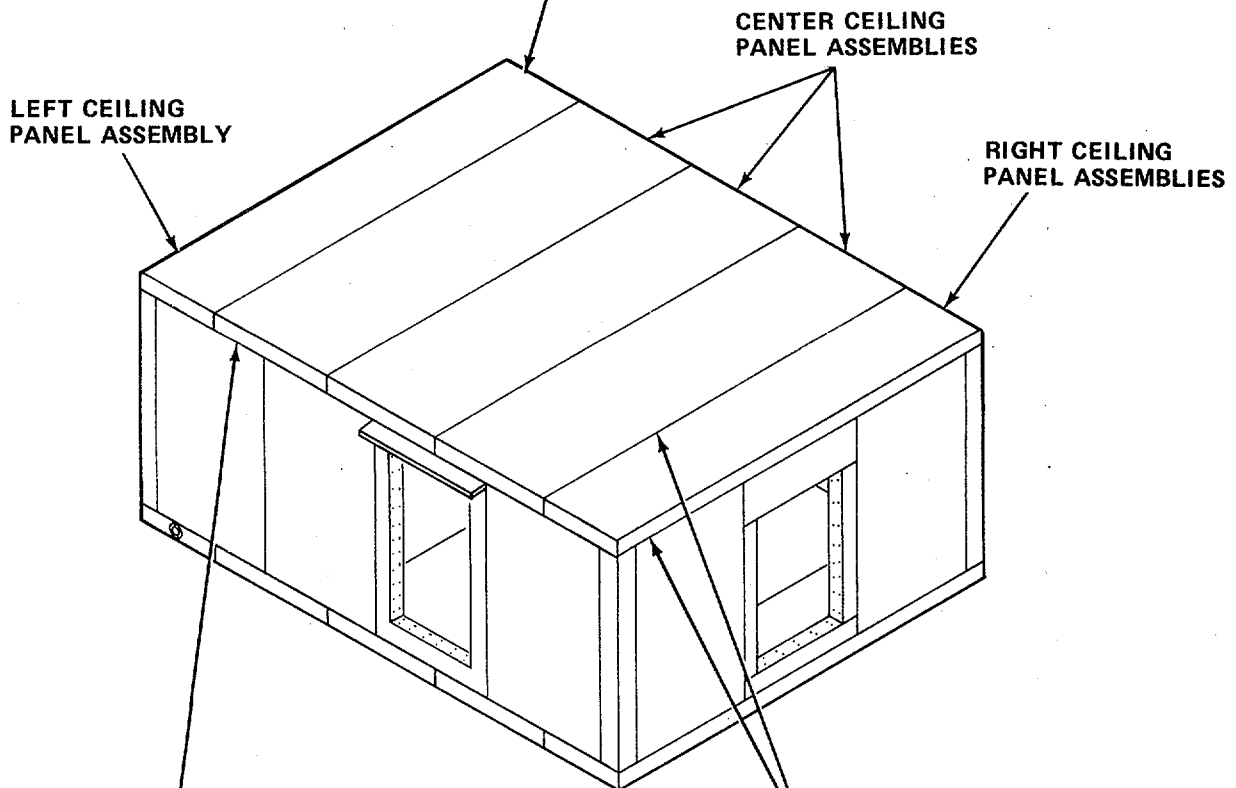

7. Once all ceiling panel assemblies are locked together, lock wall panel assemblies to ceiling panel assemblies beginning with any corner and continuing around refrigerator to the point of beginning.

8. Seal all exterior ceiling joints, and points between ceiling and wall structure panel assemblies with four-inch tape (item 11, Appx E).

9. Install bulb and globe on fixture.

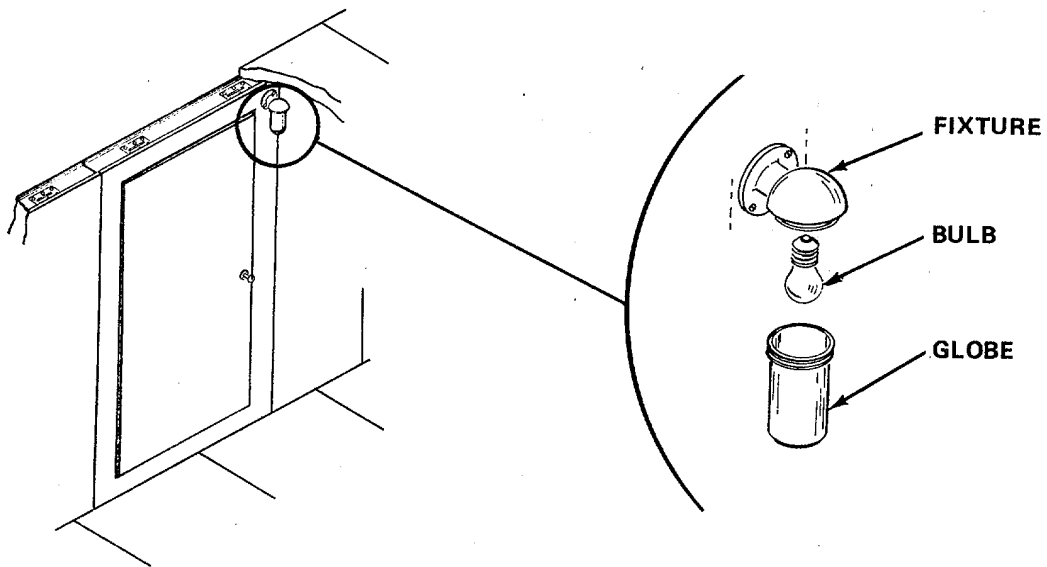

10. Attach thermometer to interior side of door frame panel assembly using two screws.

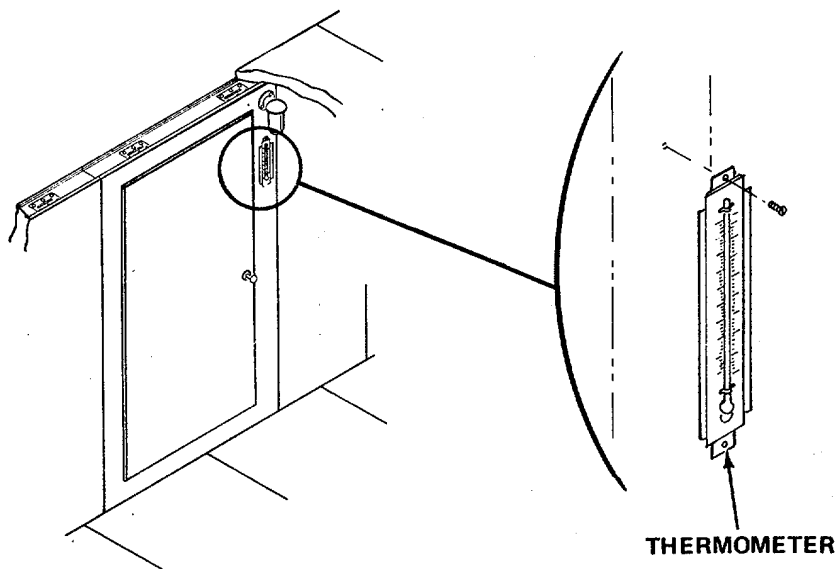

NOTE

Power supply cord must be locally manufactured to desired length from 14/3 AWG, NSN 6145-00-117-8859 or equivalent.

11. Slide boot and female receptacle cap section over power supply cord.

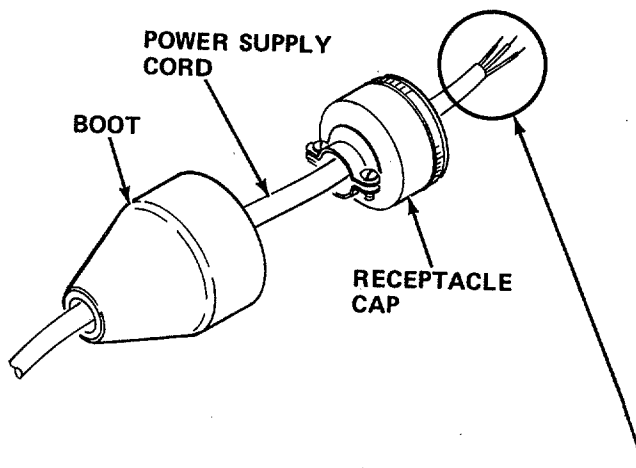

12. Strip outer insulation of power supply cord about 1 inch (25.4 mm). Strip about 1/2 inch (12.70 mm) insulation off each of the three leads.

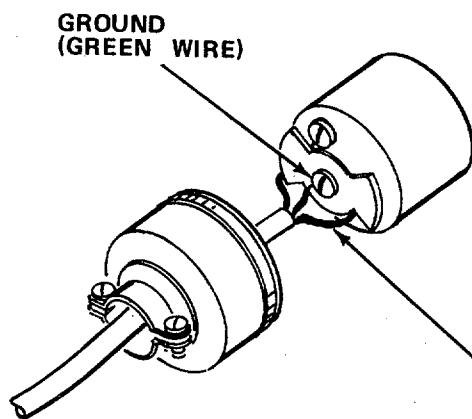

13. Connect power supply wire leads to terminals of female receptacle per the diagram shown in para. 3-8.

14. Snap receptacle and cap together. Tighten screws on clamp to secure power supply cord.

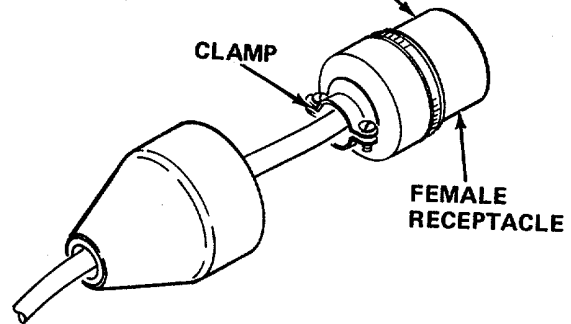

15. Slide and snap boot over assembled receptacle.

16. Unplug cap from male receptacle on door frame panel assembly and plug in the female receptacle.

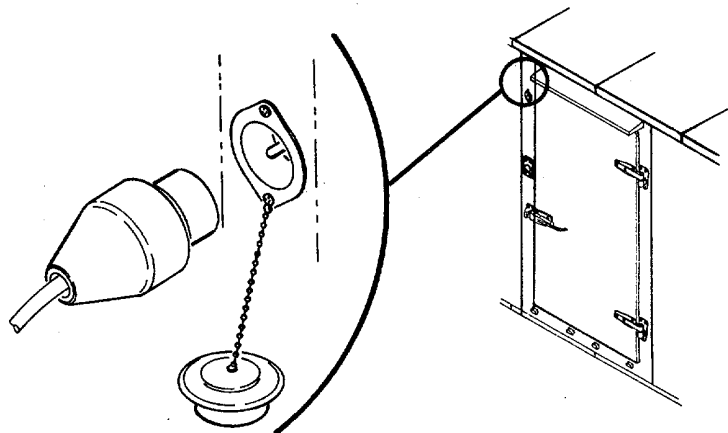

17. Install large and small floor racks inside completed refrigerator.

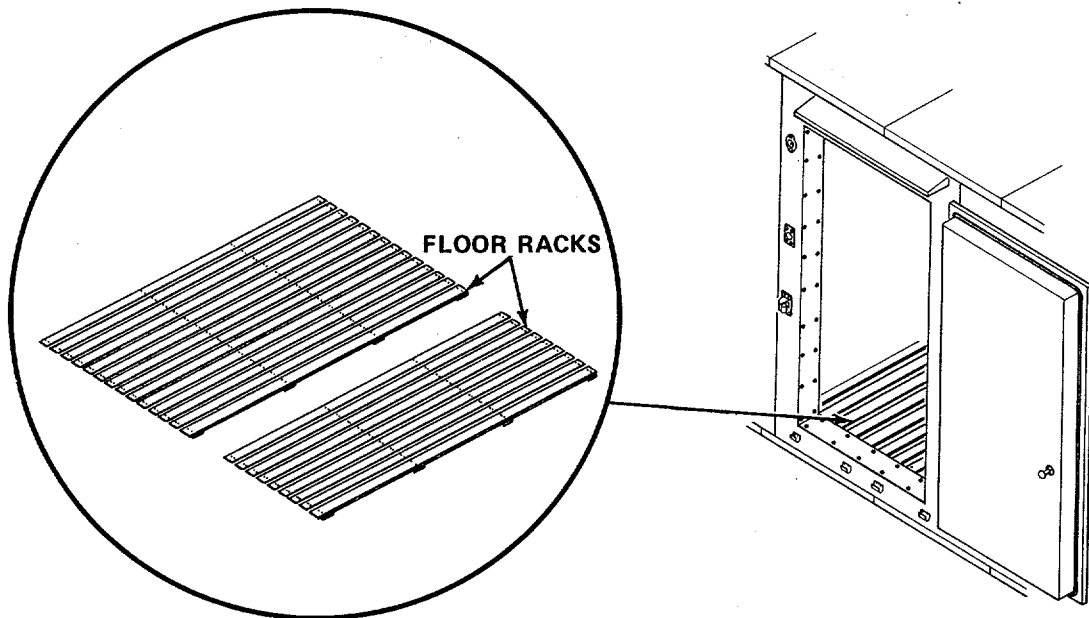

- 3-8. ELECTRICAL WIRING.** Refer to the wiring diagram below when installing and connecting electrical components of the prefabricated refrigerator.

CAUTION

Green wire must always be connected to ground terminal.

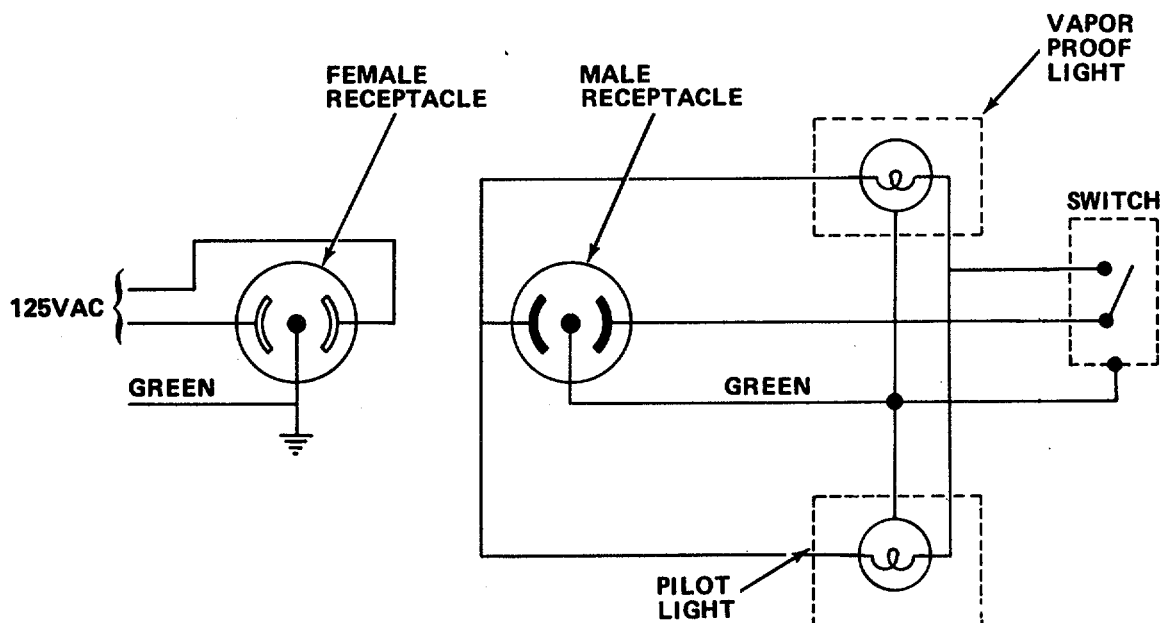

3-9. PRELIMINARY SERVICING AND ADJUSTMENT OF EQUIPMENT.

- A. Check that walk-in door opens and closes properly from inside and outside. Lubricate door hinges if needed.
- B. Check that all panel camlocks are securely tightened.
- C. Check that four-inch tape (item 11, Appx E) is properly installed at top panel joints of unit.
- D. Check vapor proof light fixture, switch cover receptacle, and thermometer for secure mounting.

Section IV. PREVENTIVE MAINTENANCE CHECKS AND SERVICES (PMCS)

- 3-10.** There are no preventive maintenance checks or services. All preventive maintenance checks (inspections) and service actions are performed at operator level.

Section V. TROUBLESHOOTING

- 3-11.** This table lists the common malfunctions which you may find during the operation or maintenance of the refrigerator or its components. You should perform the tests/inspections and corrective actions in the order listed. This manual cannot list all malfunctions that may occur; nor all tests and inspections or corrective actions. If a malfunction is not listed or is not corrected by listed corrective actions, notify your supervisor. Only those checks and corrective actions which are authorized for organizational maintenance are listed.

WARNING

The lighting circuit operates on 125V ac. Disconnect power from power receptacle before performing troubleshooting procedures. Failure to heed this warning may result in death or serious injury.

Malfunction

Test or Inspection

Corrective Action

- | | |
|----|--|
| 1. | VAPOR PROOF LIGHT WORK, PILOT LIGHT FAILS, WHEN SWITCH IS SET TO ON. |
|----|--|

Step 1:	Remove switch cover and switch. Test pilot light leads at switch connections for continuity per para 3-35. Replace pilot light housing assembly if multimeter indicates infinite resistance in accordance with para 3-33.
---------	---

Step 1:	Remove pilot light cover and pilot light housing. Test pilot light leads for continuity per para. 3-35.
---------	---

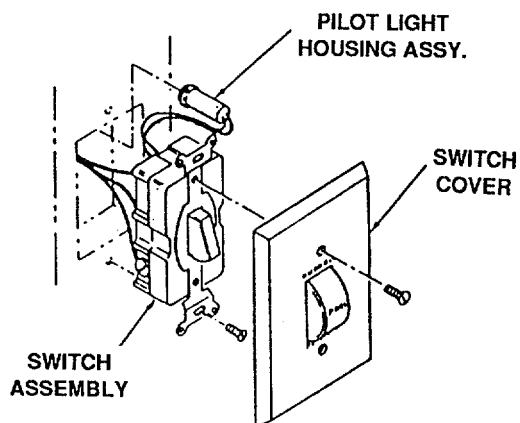

MODEL
TKR1200C

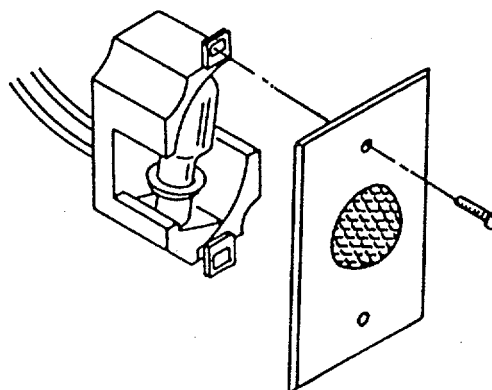

MODEL
REF 1200

Malfunction

Test or Inspection

Corrective Action

1. VAPOR PROOF LIGHT WORK, PILOT LIGHT FAILS, WHEN SWITCH IS SET TO ON (CONTINUED).

Step 2. Use multimeter to check wire continuity between pilot light terminal and male receptacle terminals as shown.

Replace door frame panel assembly per para. 3-29 if multimeter indicates infinite resistance.

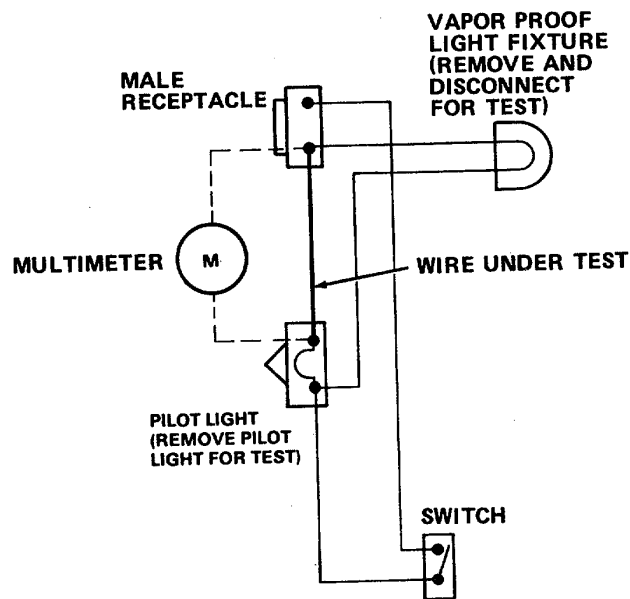

2. PILOT LIGHT WORKS, VAPOR PROOF LIGHT FAILS, WHEN SWITCH IS SET TO ON.

Step 1. Remove globe and bulb. Check for burnt out bulb. With multimeter perform continuity check on bulb. Replace burnt out bulb.

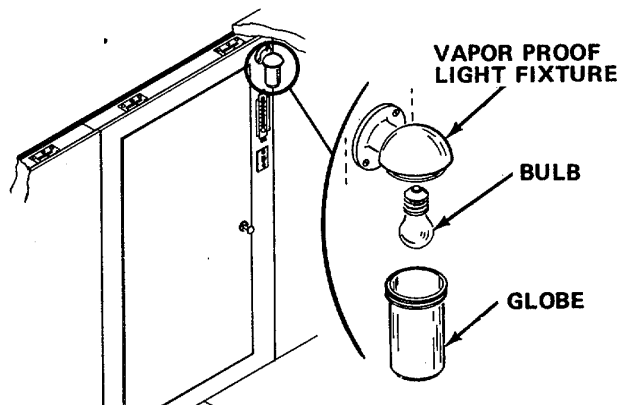

Malfunction

Test or Inspection

Corrective Action

2. PILOT LIGHT WORKS, VAPOR PROOF LIGHT FAILS, WHEN SWITCH IS SET TO ON (CONTINUED).

Step 2. If bulb is working, inspect vapor proof light socket for corroded light terminals, or dirt or dust accumulations, shorts or damage.

Clean terminals, replace light fixture if damaged per para. 3-36.

Step 3. Remove light fixture to gain access to wiring. Use multimeter to check wiring continuity between pilot light wire terminal and wire at vapor proof light fixture.

Replace door frame panel assembly per para. 3-29 if wiring is defective.

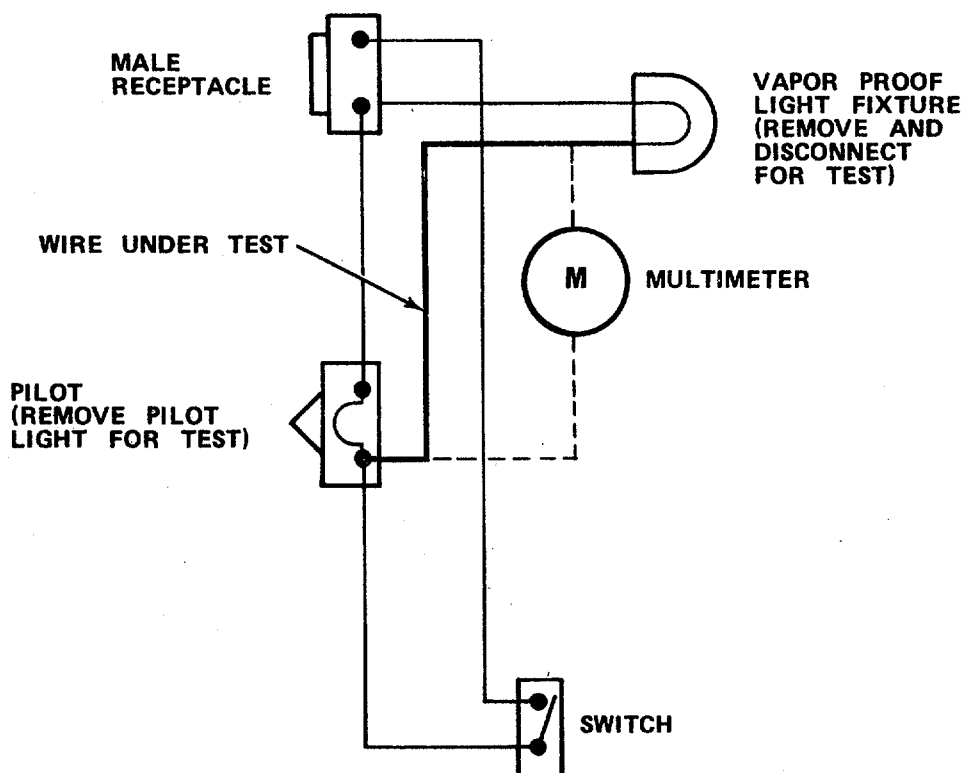

Step 4. Use multimeter to check continuity of wire between vapor proof light socket and receptacle.

Malfunction	Test or Inspection	Corrective Action
-------------	--------------------	-------------------

2. PILOT LIGHT WORKS, VAPOR PROOF LIGHT FAILS, WHEN SWITCH IS SET TO ON. (CONTINUED).

Replace door frame panel assembly, if wiring is defective per para. 3-29.

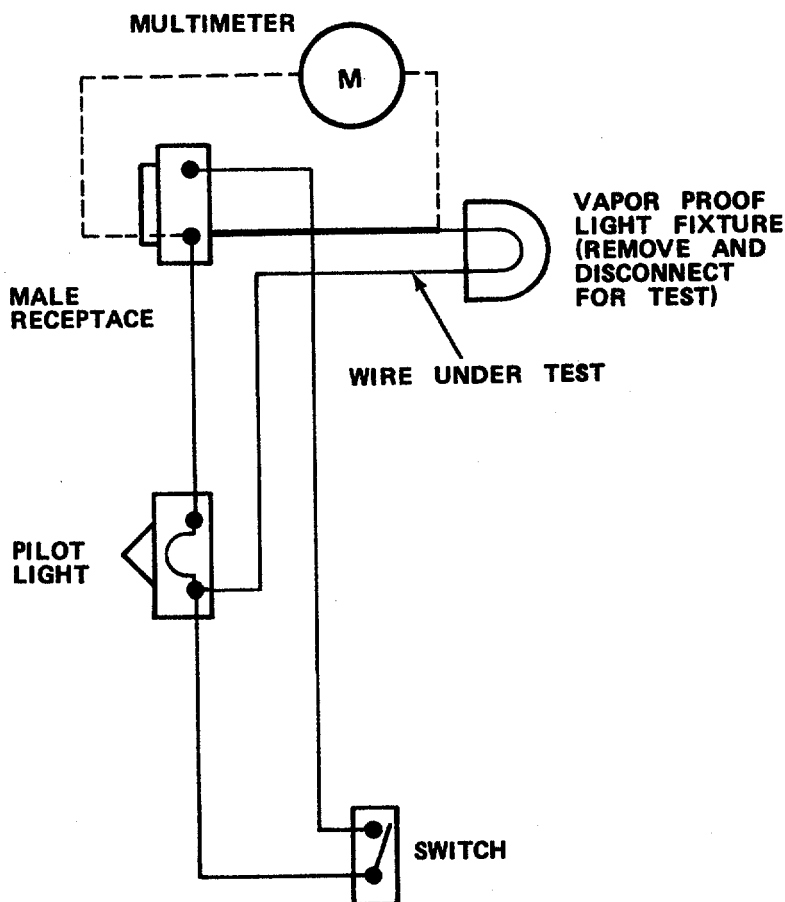

Step 5. Test vapor proof light socket per para. 3-37.

Replace vapor proof light fixture per para. 3-36.

3. NEITHER PILOT LIGHT NOR VAPOR PROOF LIGHT WORKS WHEN SWITCH IS SET TO ON.

Step 1. Unplug female receptacle. With power supply on, check for voltage at female receptacle terminals with multimeter.

Malfunction

Test or Inspection

Corrective Action

3. NEITHER PILOT LIGHT NOR VAPOR PROOF LIGHT WORKS WHEN SWITCH IS SET TO ON (CONTINUED).

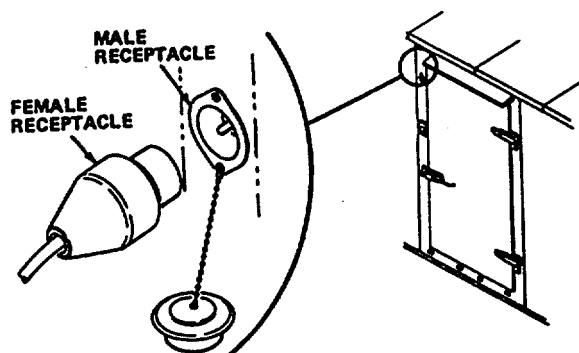

If voltage is not present, turn off power supply. Check female receptacle wiring connections for signs of shorts and secureness. Secure connections as needed. If connections are secure, disconnect cord from power supply and check wires for continuity with multimeter. Replace power supply cord if defective.

Step 2. Test male receptacle per para. 3-35.

Replace receptacle per para. 3-34 if damaged or defective.



MALE RECEPTACLE

Step 3. Test switch per para. 3-39.

Replace switch if defective per para. 3-38.

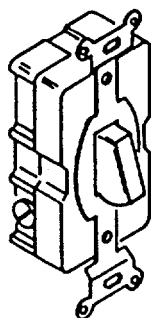

**MODEL
TKR1200C**

SWITCH

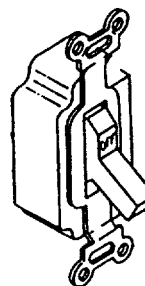

**MODEL
REF 1200**

Malfunction

Test or Inspection

Corrective Action

3. NEITHER PILOT LIGHT NOR VAPOR PROOF LIGHT WORKS WHEN SWITCH IS SET TO ON (CONTINUED).

Step 4. If power cord, female receptacle, male receptacle, and switch check out OK, door frame panel assembly wiring is defective.

Replace door frame panel assembly per para. 3-29.

Section VI. UNIT MAINTENANCE PROCEDURES

3-12. PROCEDURES.

3-13. SUMMARY PROCEDURES.

A. INITIAL SETUP.

Test Equipment

Multimeter AN/PSM-45

TOOLS: Screwdriver, Flat Tip
Screwdriver, Philips Head
Hex Wrench (4, supplied
with refrigerator)
Knife, Pocket

Materials

Four-inch Sealing Tape
(item 11, Appx E)

Personnel Required (4)
Two or three persons to
position panel assemblies.
One or two to lock camlocks.

3-14. REPLACEMENT OF RIGHT, CENTER, AND LEFT CEILING PANEL ASSEMBLIES, AND DOOR CANOPY.

TOOLS: Hex Wrench

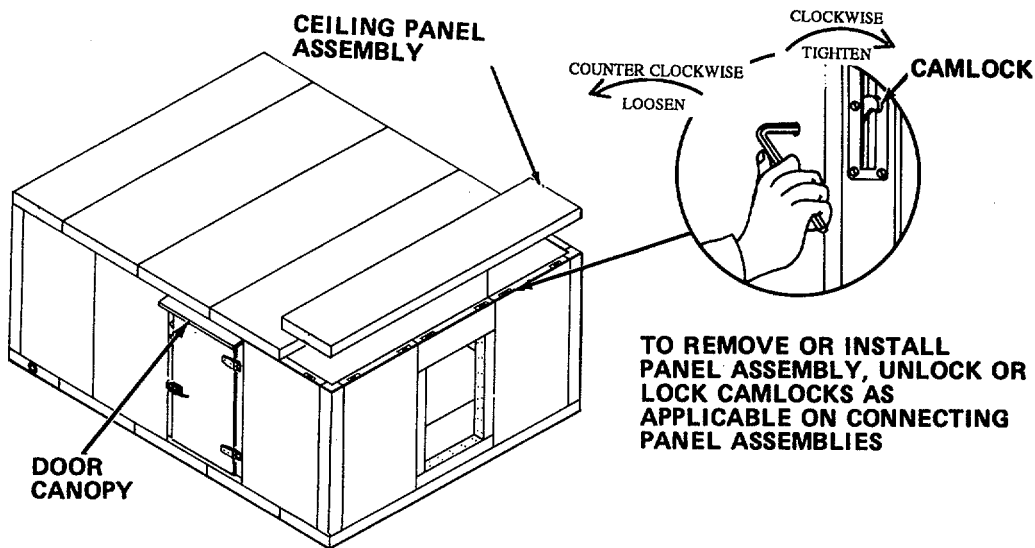

REMOVAL

1. Remove sealing tape from top and side joints of ceiling panel assembly requiring replacement.
2. Unlock camlocks, as applicable, on ceiling panel assembly to be removed and/or on adjacent ceiling panel assembly using hex wrench.
3. Unlock camlocks on ceiling ends of supporting wall structure panel assembly(s) as applicable.
4. Remove ceiling panel assembly requiring replacement.
5. To remove door canopy, remove applicable ceiling panel assemblies per steps 1 through 3, above. Then remove door canopy.

INSTALLATION

CAUTION

Exercise caution when installing a panel assembly to prevent damage to camlocks and gasket panels on replacement assembly and on connecting panel assemblies. Be sure camlocks on replacement assembly and connecting panel assemblies are fully retracted before positioning the replacement panel assembly.

1. Position replacement ceiling panel assembly gasket side down on refrigerator. If door canopy is being replaced, first hang door canopy over door frame panel assembly.

2. Lock replacement ceiling panel assembly to adjacent ceiling panel assembly by rotating camlocks fully clockwise.
3. Lock ceiling ends of supporting wall structure panel assemblies as applicable, to the replacement ceiling panel assembly by turning camlocks on upper end of wall units fully clockwise.
4. Apply new sealing tape (item 11, Appx E) over top and side joints of replacement ceiling panel assembly.

3-15. REMOVE/INSTALL STRAINER.

TOOLS: Screwdriver, Cross Tip

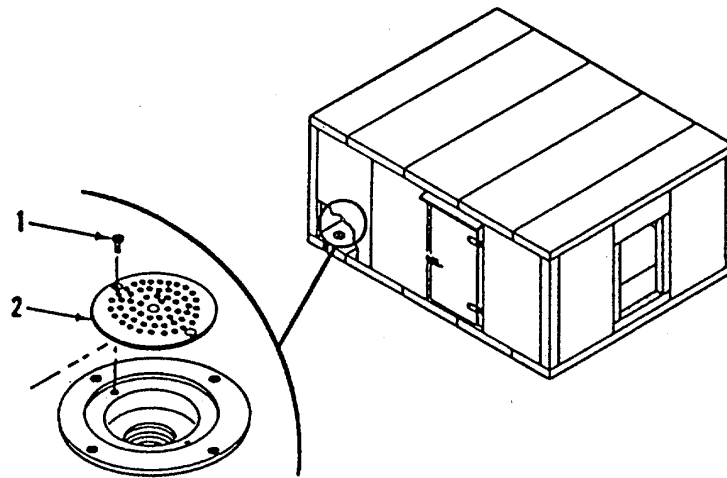

TYPICAL: 2 PLACES

REMOVAL

1. Remove two screws (1) with screwdriver.
2. Lift strainer (2) out of basin.

INSTALLATION

1. Position replacement strainer (1) over floor or ceiling drain.
2. Attach strainer (2) to drain using two screws(1).

3-16. REMOVE/INSTALL OUTSIDE DRAIN.

TOOLS: Screwdriver, Cross Tip

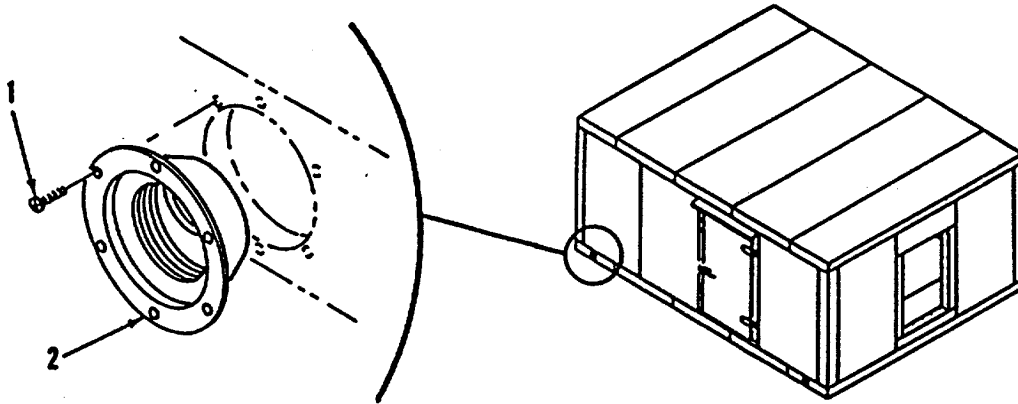

TYPICAL: 2 PLACES

REMOVAL

1. Remove six screws (1) using screwdriver.
2. Remove outside drain (2).

INSTALLATION

1. Position outside drain (2) onto panel assembly.
2. Secure in place with six screws (1).

3-17. INSPECT GASKET PANEL.

NOTE

Perform gasket panel inspection only if refrigerator unit is completely disassembled or if a panel assembly is removed.

PRELIMINARY PROCEDURE: Remove ceiling panel assembly (para. 3-14), wall structure panel assembly (para. 3-29), or floor panel assembly (para. 3-44).

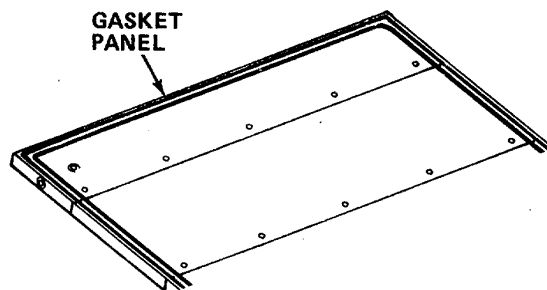

INSPECTION

1. Inspect gasket panels or removed panel assembly and/or the immediately connecting panel assembly(s) as applicable.
2. Check gasket panels for deterioration, cracks, tears, breaks, missing sections, or other damage. Replace as needed per para. 3-18.

3-18. REMOVE/INSTALL GASKET PANEL.

TOOLS: Staple Remover
Staple Gun
Tape Measure
SUPPLIES: Gasket Material
Staples

NOTE

PRELIMINARY PROCEDURE: Inspect gasket panel per para. 3-17.

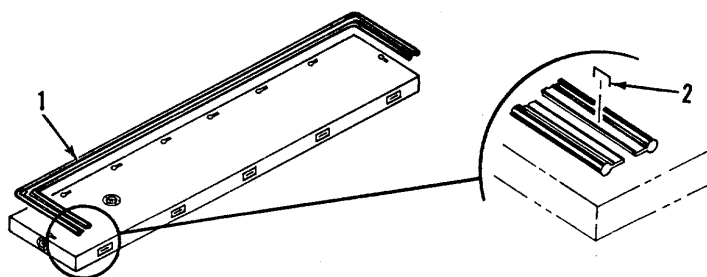

REMOVAL

1. Note position of gasket panels (1) on panel assembly requiring gasket replacement.
2. With tape measure, note and record length of gasket panel requiring replacement.
3. Strip damaged gasket panels (1) from panel assembly by removing staples with stable remover.

INSTALLATION

1. Cut gasket panels to sufficient lengths as recorded for a continuous run.
2. Install replacement gasket panel on panel assembly using staple gun with staples spaced 1 1/2" (54 mm) apart.

3-19 INSPECT CAMLOCK.

TOOLS: Hex Wrench

NOTE

Inspect camlocks only if refrigerator unit is completely disassembled or if a panel assembly is removed.

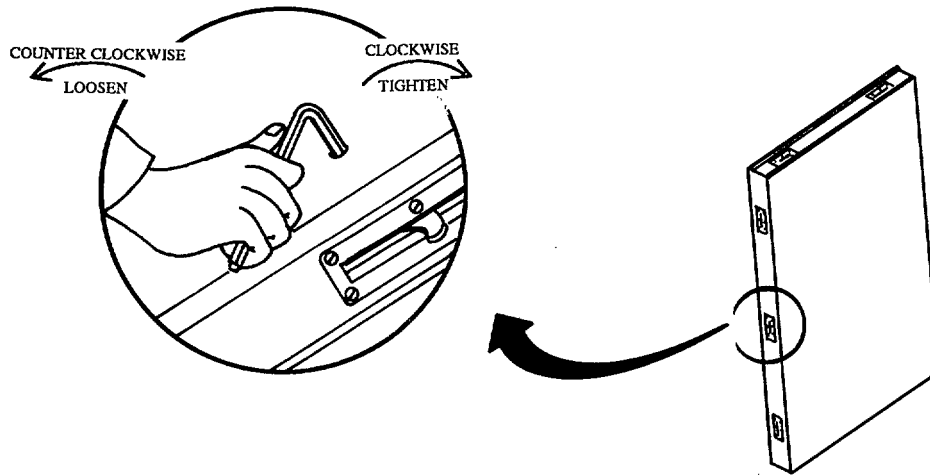

INSPECTION

1. With hex wrench, check for proper operation by rotating camlock clockwise to extend and counterclockwise to retract.
2. Check for excessive binding. Check camlock hook for wear and other damage. Replace camlock if excessive binding or damage is noted.

3-20. REMOVE/INSTALL CAMLOCK.

TOOLS: Screwdriver, Cross Tip

NOTE

PRELIMINARY PROCEDURE: Inspect camlock per para. 3-19.

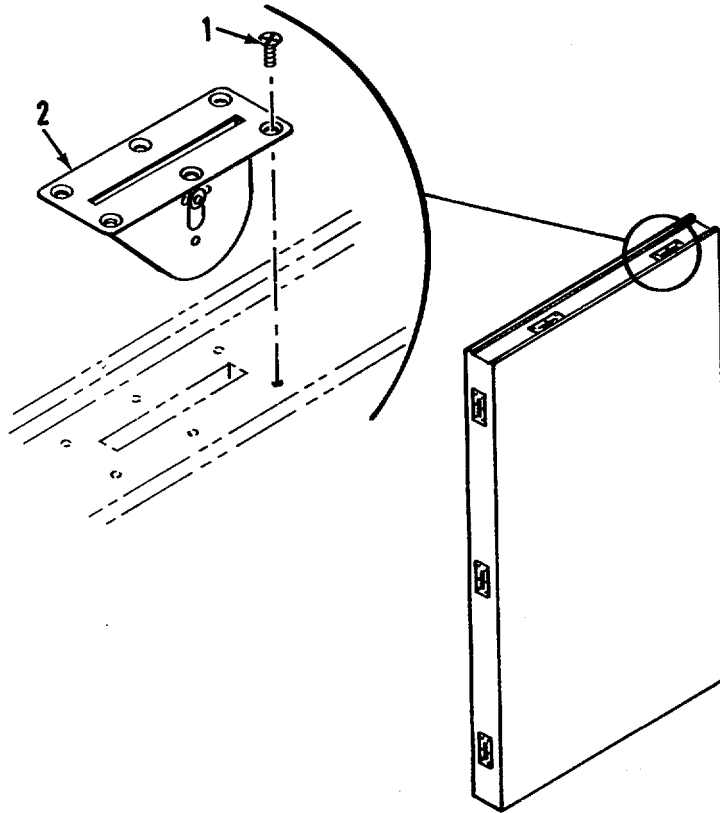

REMOVAL

1. Remove six screws (1).
2. Remove camlock (2) from panel assembly.

INSTALLATION

1. Position camlock (2) onto panel assembly.
2. Secure camlock in place with six screws (1).

3-21. REMOVE/INSTALL WALK-IN DOOR ASSEMBLY.

TOOLS: Screwdriver, Flat Tip

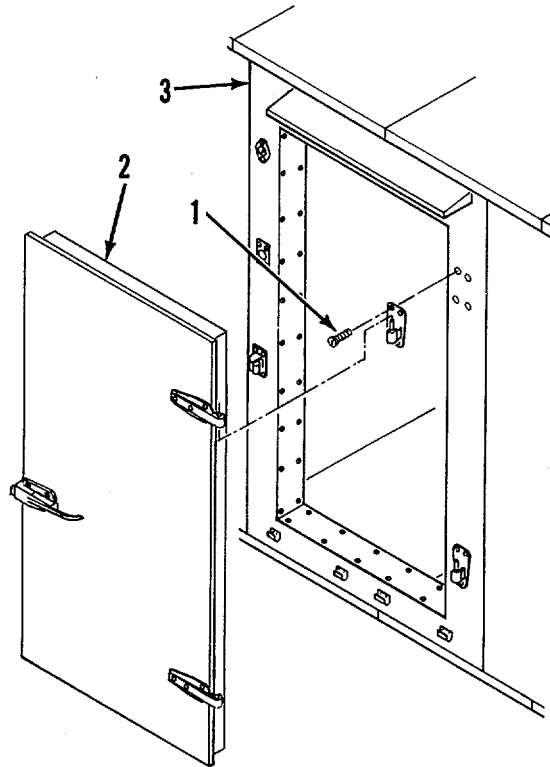

REMOVAL

1. Lift and remove door (2) from hinges.
2. Remove screws (1) holding lower and upper hinges to door frame panel assembly (3).

INSTALLATION

1. Thread screws (1) through upper and lower hinges and into door frame panel assembly (3).
2. Install door in hinges.
3. Close and latch door. Check door gasket for even sealing around door.
4. Check latch for proper alignment.
5. Tighten screws (1) securely.

3-22. REMOVE/INSTALL PADLOCK AND CHAIN.

TOOLS: Screwdriver, Cross Tip

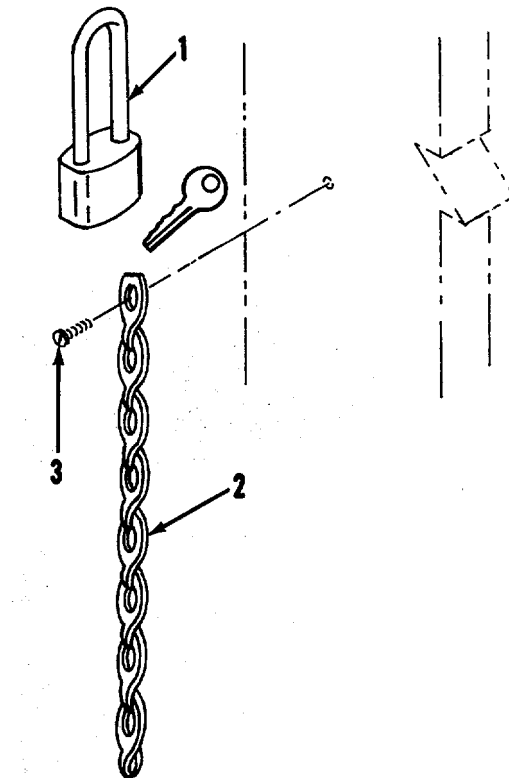

REMOVAL

1. Unlock padlock (1) with key (2) and remove padlock (1).
2. Remove screw (3).
3. Remove chain (4).

INSTALLATION

1. Position chain (4) on door and secure with screw (3).
2. Attach padlock (1).

3-23. REPAIR LATCH.

TOOLS: Screwdriver, Flat Tip

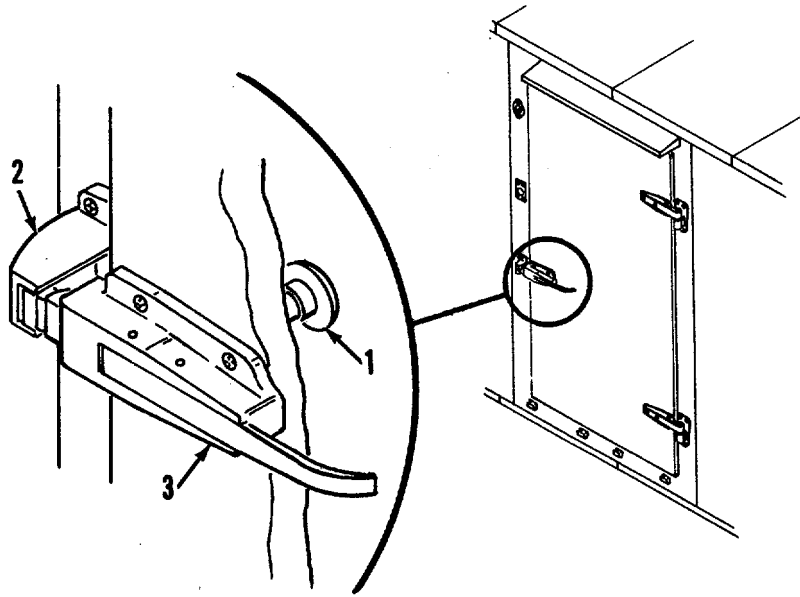

REMOVAL

1. Remove pushrod (1) from walk-in door assembly per para. 3-25.
2. Remove strike (2) from exterior side of door frame panel assembly per para.3-24.
3. Remove latch (3) from exterior side of walk-in door assembly per para. 3-25.

INSTALLATION

1. Install latch (3) on walk-in door assembly per para. 3-25
2. Install strike (2) on door frame assembly per para. 3-24.
3. Install pushrod (1) on interior side of walk-in door assembly per para. 3-25

3-24. REMOVE/INSTALLATION LATCH STRIKE.

TOOLS: Screwdriver, Flat Tip

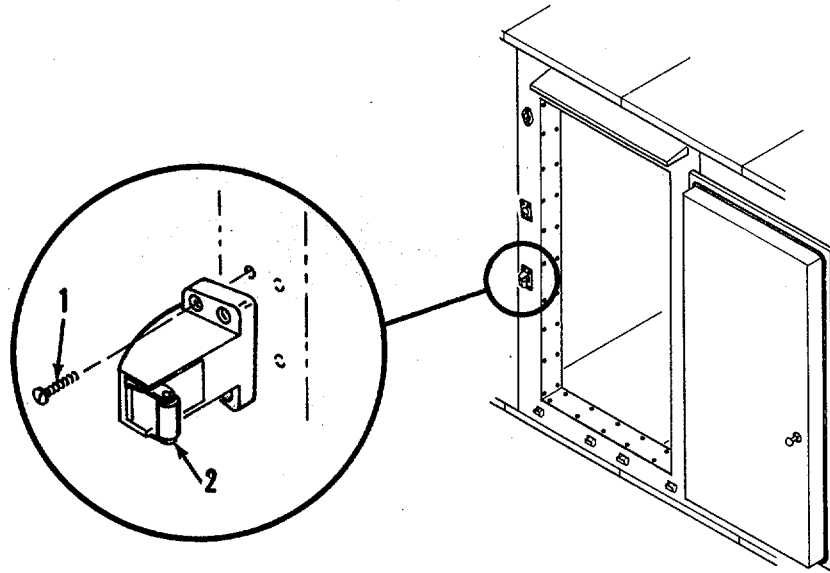

REMOVAL

1. Remove screws (1) to loosen strike.
2. Remove strike (2) from door frame panel assembly.

INSTALLATION

1. Position strike (2) on external side of door frame panel assembly.
2. Insert screws (1) through strike and into door frame panel assembly. Do not tighten.
3. Close door to ensure that latch engages properly.
4. Tighten screws (1).
5. Check gasket around walk-in door to be sure it is sealing properly.

3-25. REMOVE/INSTALL LATCH.

TOOLS: Screwdriver, Flat Tip

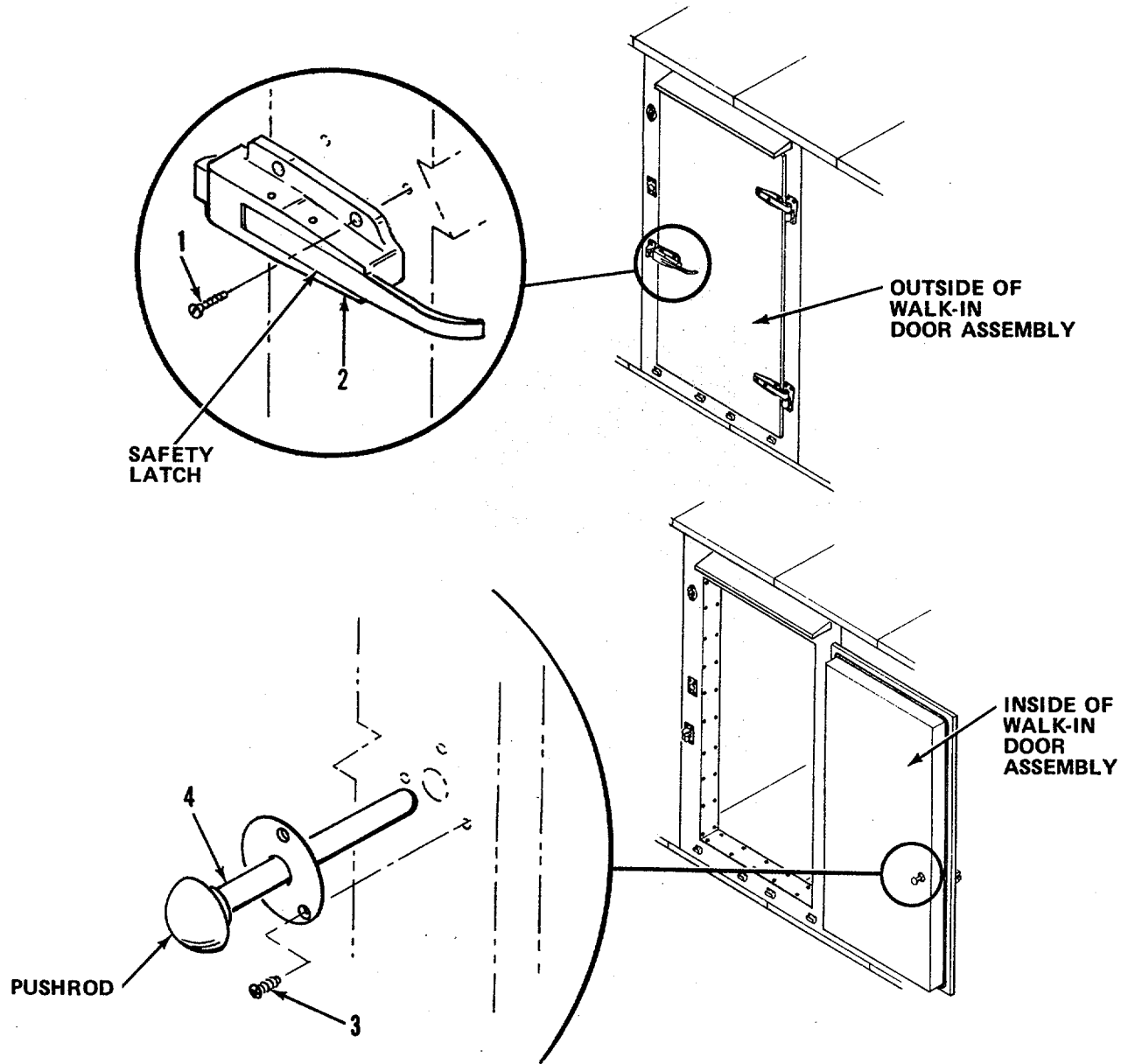

REMOVAL

1. Remove screws(1).
2. Remove safety latch (2) from outside of walk-in door assembly.
3. Remove screws (3), and mounting plate.
4. Remove pushrod (4) from inside of walk-in door assembly.

INSTALLATION

1. Position safety latch (2) on outside of walk-in door assembly.
2. Thread screws (1) through latch and into walk-in door assembly. Do not tighten screws.
3. Align latch and latch strike.
4. Tighten screws (1) securely.
5. Position pushrod (4) inside of walk-in door assembly.
6. Thread screws (3) through mounting plate into walk-in door assembly. Do not tighten screws.
7. Be sure that pushrod will operate safety latch.
8. Tighten screws (3) securely.

3-26. REMOVE/INSTALL HINGE.

TOOLS: Screwdriver, Flat Tip

NOTE

If both hinges are damaged, perform PRELIMINARY PROCEDURES: Door removal (para. 3-21).

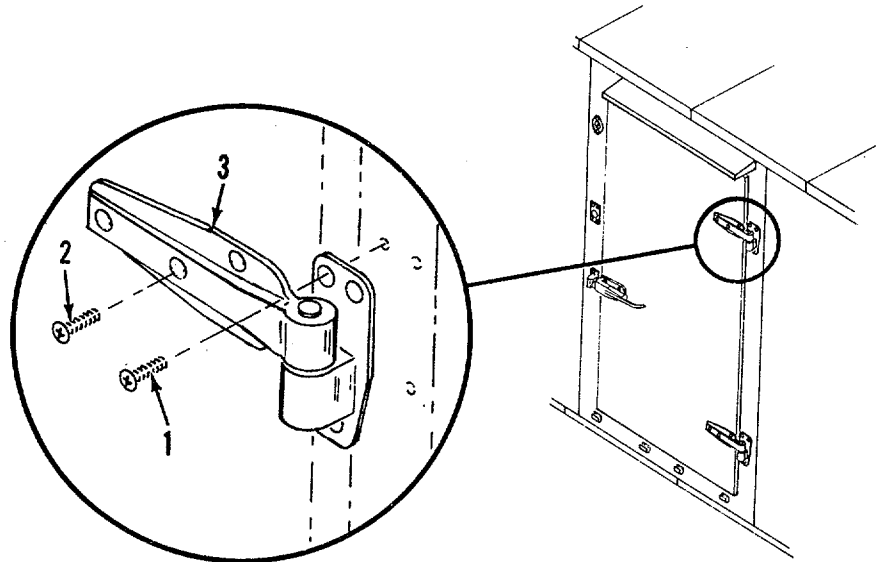

REMOVAL

1. Remove screws (1) and (2) using screwdriver.
2. Remove hinge (3).

INSTALLATION

1. Position hinge (3) on walk-in door assembly and secure with screws (2) using screwdriver.

NOTE

If both hinges are being replaced, perform FOLLOW-ON MAINTENANCE: Install door (Para. 3-21).

2. Insert screws (1) through hinge (3) and into door frame panel assembly.
3. Close and latch door. Tighten screws (1) securely with screwdriver.

3-27. REMOVE/INSTALL DOOR GASKET.

TOOLS: Staple Puller or Screwdriver, Flat Tip
Pocket Knife
Staple Gun

SUPPLIES: Gasket
Staples

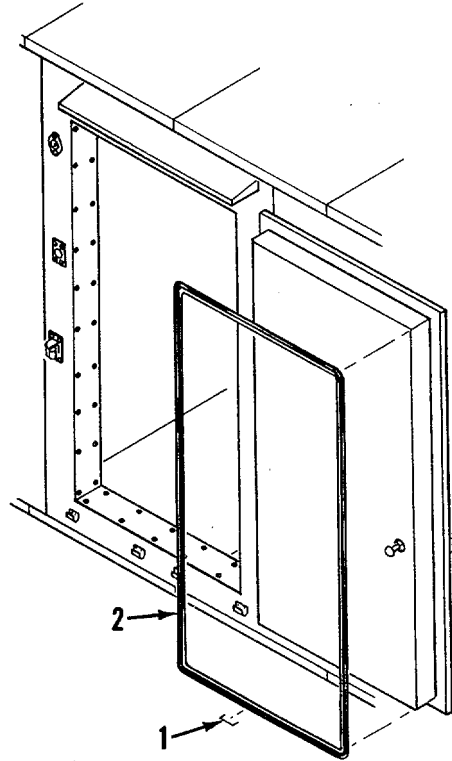

REMOVAL

1. Use screwdriver or staple puller to remove staples (1).
2. Remove and discard damaged gasket (2).

INSTALLATION

1. Begin installing new gasket on the bottom, hinge side, of the door using staple gun to mount the gasket.
2. Gasket must be installed as a continuous strip around door and end at the bottom, hinge side, of the door. Cut excess after tacking end into place.

3-28. REMOVE/INSTALL DECALMANIA.

TOOLS: Pocket Knife

SUPPLIES: Decalmania

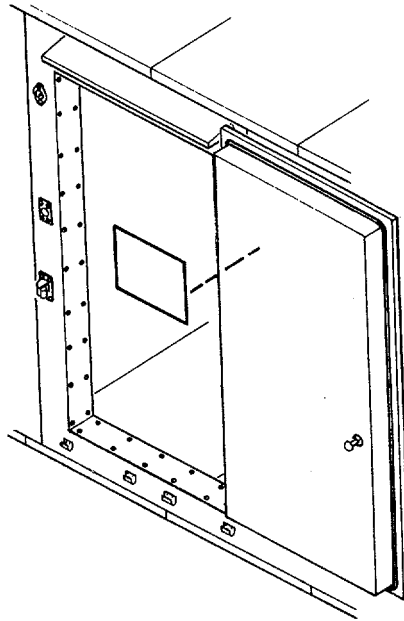

REMOVAL

1. Open refrigerator walk-in door.
2. With pocket knife pry off one corner of decalmania and peel off refrigerator walk-in door.
3. With solvent (item 10, Appx E) remove any remaining adhesive material from walk-in door.

INSTALLATION

1. Peel backing off replacement decalmania.
2. Position replacement decalmania on interior side of refrigerator walk-in door and press into place.
3. Using hands, apply steady pressure across entire surface of decalmania to ensure uniform adhesion.

3-29. REPLACEMENT OF WALL STRUCTURE PANEL ASSEMBLY (CORNER, STANDARD, EVAPORATOR AND DOOR FRAME PANEL ASSEMBLIES).

TOOLS: Hex Wrench

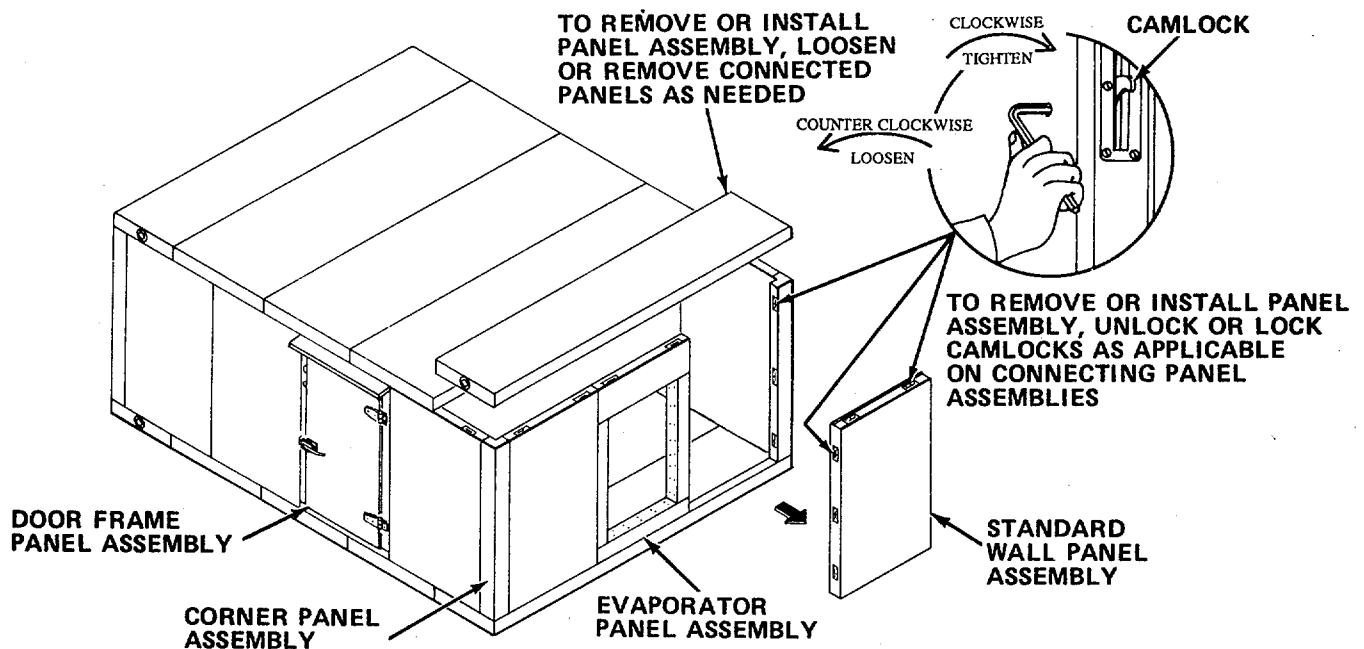

NOTE

Removal or installation of wall structure panel assembly (standard, corner, evaporator, or door frame panel assembly) may require loosening or removal of other connected ceiling or wall panel assemblies. If door frame panel assembly is to be removed, first remove walk-in door, vapor proof light fixture, and thermometer. Tape pads over receptacles, switch, and pilot light to prevent damage.

REMOVAL

1. Remove sealing tape from external ceiling ends of wall structure panel assembly to be replaced
2. Unlock camlocks at ceiling and floor ends of wall structure panel assembly requiring replacement.
3. Unlock camlocks connecting the panel assembly to adjacent wall structure panel assemblies.
4. Remove wall panel assembly. If needed, loosen or remove connected ceiling panel assembly and/or wall panel assembly to allow easy removal or installation.

INSTALLATION

1. Position replacement wall panel assembly. If removed, position any connecting wall panel assembly. Lock together adjacent wall panel assemblies.
2. With wall assemblies locked together, lock floor ends of wall panel assemblies to the floor panel assembly(s).

3. If loosened or removed, reposition ceiling panel assembly and lock ceiling ends of wall panel assembly(s) to ceiling.
4. Apply new sealing tape over applicable ceiling and wall panel assembly joints.

3-30. REMOVE/INSTALL FEMALE RECEPTACLE.

TOOLS: Screwdriver, Flat Tip
Pocket Knife

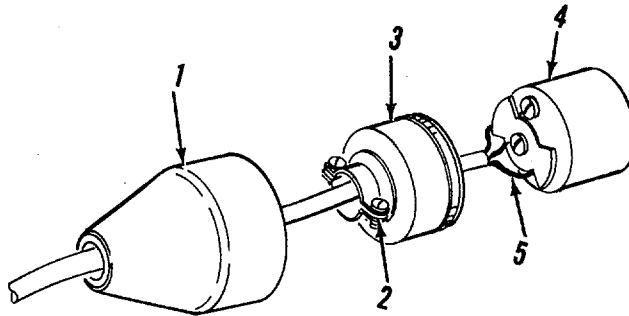

WARNING

The lighting circuit operates on 125V ac. Shut off power supply at its source before beginning this procedure or disconnect power cable from source. Failure to heed this warning may result in death or injury.

REMOVAL

1. Slide boot (1) off female receptacle (4).
2. Loosen retaining clamp screws (2) with screwdriver.
3. Separate halves (3 and 4) of female receptacle.
4. Tag and disconnect wires (5) to female receptacle.

INSTALLATION

1. Slide cap (3) of female receptacle onto the power cord.
2. Connect wires (5) to terminals of female receptacle.
3. Snap halves (3 and 4) of female receptacle together.
4. Using screwdriver, tighten screws (2) to secure power supply cord to clamp.
5. Slide boot (1) over female receptacle.

3-31. TEST FEMALE RECEPTACLE.

TOOLS: Digital Multimeter

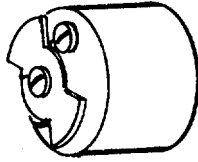

NOTE

PRELIMINARY PROCEDURE: Remove female receptacle (para. 3-30).

PROCEDURE

1. With multimeter, check for isolation across both receptacle wire terminals and across each wire terminal and the ground terminal. Multimeter shall indicate infinite resistance. Otherwise receptacle is damaged and shall be replaced.
2. With multimeter, check for continuity across each wire terminal at rear of connector and its corresponding plug terminal at the front end. Multimeter shall indicate continuity.

NOTE

FOLLOW-ON MAINTENANCE: Install female receptacle (para. 3-30).

3-32. REMOVE/INSTALL PILOT LIGHT HOUSING ASSEMBLY.

TOOLS: Screwdriver, Flat Tip

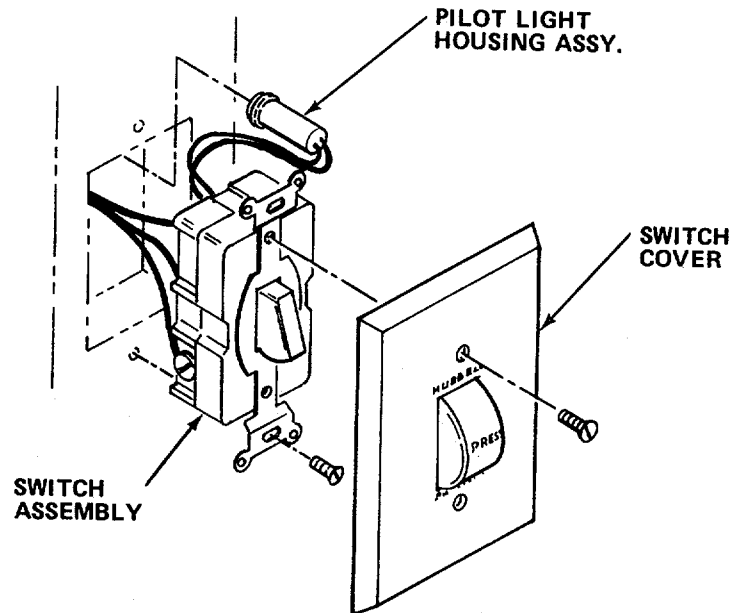

REMOVAL

WARNING

The lighting circuit operates on 125V ac. Disconnect power to power receptacle before beginning this procedure. Failure to heed this warning may result in death or serious injury.

1. Remove switch cover and switch assembly.
2. Carefully pull out switch assembly from door frame panel assembly.
3. Tag and disconnect wires from switch assembly; remove pilot light housing assembly.

INSTALLATION

1. Connect replacement pilot light housing assembly wires.
2. Position switch and switch plate assembly onto door frame panel assembly.
3. Reconnect power supply cord to power receptacle.

3-32. REMOVE/INSTALL PILOT LIGHT HOUSING ASSEMBLY.

TOOLS: SCREWDRIVE, Flat Tip

FOR MODEL REF 1200

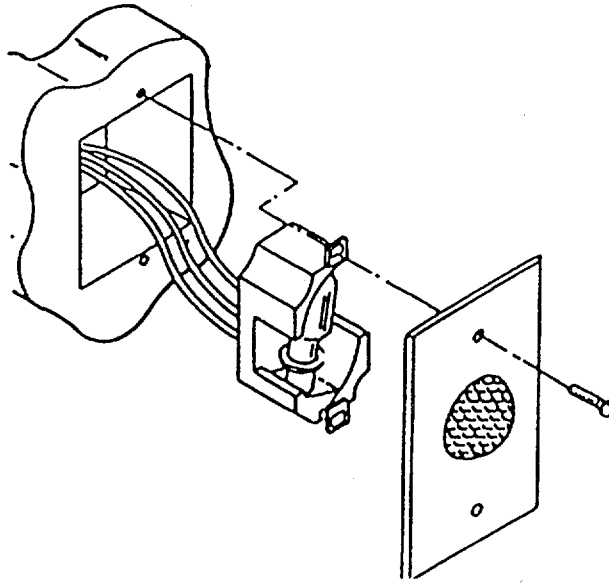

REMOVAL

WARNING

The lighting circuit operates on 125V ac. Disconnect power to power receptacle before beginning this procedure. Failure to heed this warning may result in death or serious injury.

1. Remove pilot light cover and pilot light assembly carefully from door frame.
2. Tag and disconnect wires from pilot light assembly and remove.

INSTALLATION

1. Connect tagged wires to new pilot light assembly.
2. Position and connect wires to new pilot light assembly onto door frame panel.
3. Reconnect power supply cord to power receptacle.

3-33. TEST PILOT LIGHT HOUSING ASSEMBLY.

TOOLS: Digital Multimeter

NOTE

PRELIMINARY PROCEDURE: Remove pilot light cover and pilot light housing assembly per para. 3-32.

**PILOT LIGHT
HOUSING ASSEMBLY**

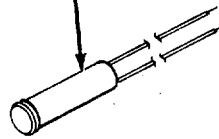

TEST

1. With multimeter, check continuity between pilot light housing assembly terminals.
2. Replace pilot light if multimeter indicates infinite resistance.

3-34. REMOVE/INSTALL MALE RECEPTACLE, CAP AND CHAIN.

TOOLS: Screwdriver, Flat Tip

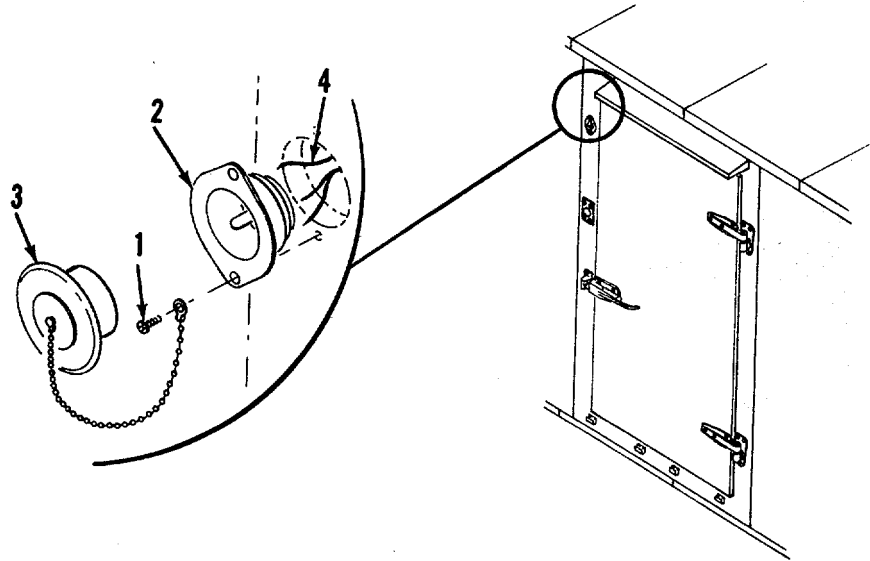

REMOVAL

WARNING

The lighting circuit operates on 125V ac. Disconnect male power receptacle before beginning this procedure. Failure to heed this warning may result in death or injury.

1. Loosen and remove screws (1) with screwdriver.
2. Gently pull male receptacle (2) and cap and chain (3) away from door frame to gain access to using panel assembly.
3. Tag and disconnect wires (4) at rear of receptacle.

INSTALLATION

1. Connect wires (4) to receptacle (2) terminals as tagged and remove wire tags.
2. Position receptacle (2) and cap and chain (3) onto door frame panel assembly. Secure with screws (1) using screwdriver.
3. Reconnect power to power receptacle.

3-35. TEST MALE RECEPTACLE.

TOOLS: Digital Multimeter

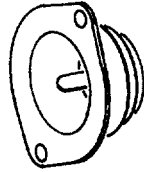

NOTE

PRELIMINARY PROCEDURE: Remove male receptacle (para.3-34).

PROCEDURE

1. With multimeter, perform isolation testing across the two plug terminals, and across each plug terminal and the ground terminal or receptacle case. Multimeter shall indicate infinite resistance across both plug terminals and across each plug terminal and the ground terminal. Otherwise, receptacle is defective and shall be replaced.

NOTE

FOLLOW-ON MAINTENANCE: INSTALL MALE RECEPTACLE (para. 3-34).

3-36. REMOVE/INSTALL VAPOR PROOF LIGHT FIXTURE.

TOOLS: Screwdriver, Flat Tip

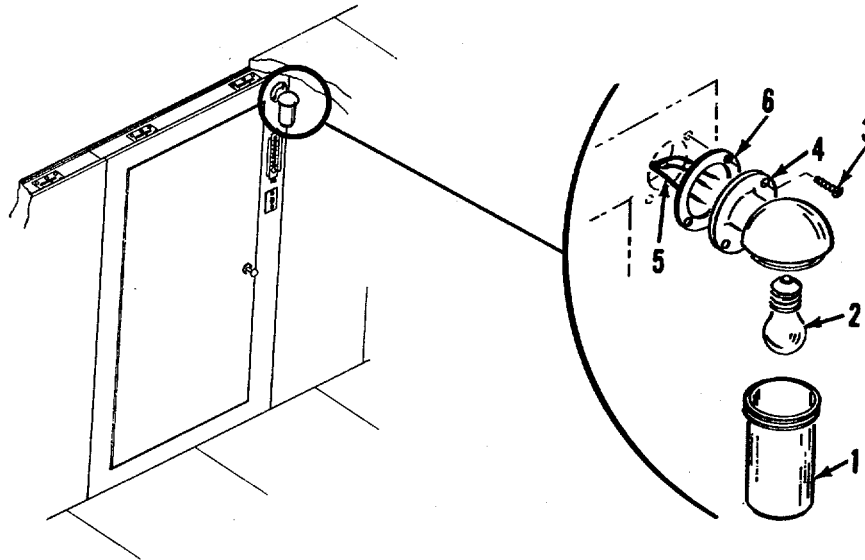

REMOVAL

WARNING

The light circuit operates on 125V ac. Disconnect power to power receptacle before beginning this procedure. Failure to heed this warning may result in death or injury.

1. Unthread and remove globe (1) and bulb (2).
2. Remove screws (3) with screwdriver and carefully pull vapor proof light fixture (4) away from door frame panel assembly.
3. Tag and disconnect wires (5) from vapor proof light fixture (4). Remove vapor proof light fixture and gasket (6).

INSTALLATION

1. Position gasket (6) over wires (5) on panel assembly. Connect wires (5) to vapor proof light fixture (4) as tagged. Remove and discard tags.
2. Thread screws (3) through vapor proof light fixture (4), gasket (6), and into door frame panel assembly. Tighten the screws (3) with screwdriver.
3. Install bulb (2) and globe (1) into vapor proof light fixture (4).
4. Reconnect power to power receptacle.

3-37. TEST VAPOR PROOF LIGHT FIXTURE.

TOOLS: Digital Multimeter

NOTE

PRELIMINARY PROCEDURE: Remove vapor proof light fixture (para. 3-36).

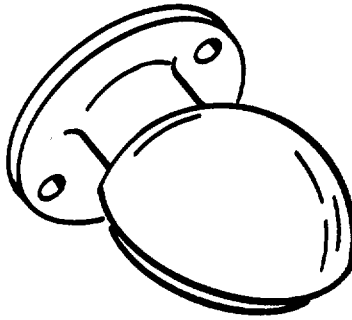

PROCEDURE

1. With multimeter, perform isolation testing across the three wire terminals at rear of the fixture.
2. Multimeter shall indicate infinite resistance across each pair of wire terminals tested. If not, fixture is defective and shall be replaced.

NOTE

FOLLOW-ON MAINTENANCE: Install vapor proof light fixture (para. 3-36).

3-38. REMOVE/INSTALL SWITCH AND SWITCH COVER.

TOOLS: Screwdriver, Flat Tip

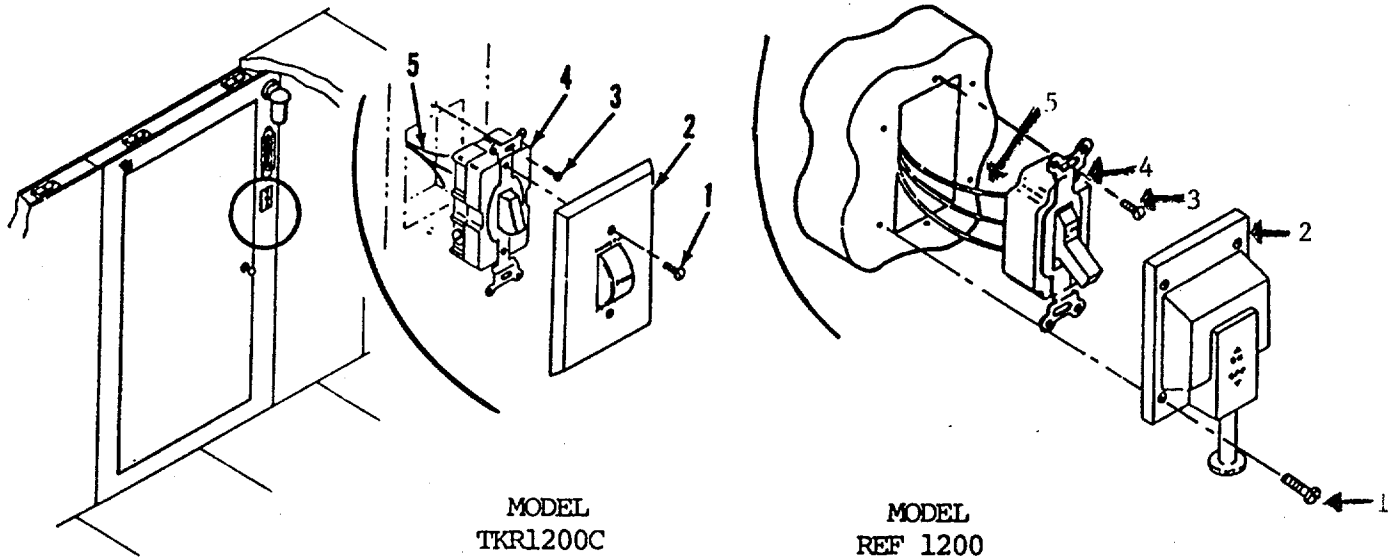

REMOVAL

REMOVAL

WARNING

The lighting circuit operates on 125V ac. Disconnect power to power receptacle before beginning this procedure. Failure to heed this warning may result in death or injury.

1. Remove screws (1) with screwdriver and remove switch cover (2).
2. Remove screws (3) and gently pull switch (4) away from door frame panel assembly.
3. Tag and disconnect wires (5) from switch.

INSTALLATION

1. Connect wires (5) to switch as tagged and remove wire tags.
2. Position switch (4) into door frame panel assembly and secure with screws (1).
3. Install switch cover (2) using two screws (1). Tighten screws with screwdriver.
4. Reconnect power to power receptacle.

3-39. TEST SWITCH.

TOOLS: Digital Multimeter

NOTE

PRELIMINARY PROCEDURE: Switch removal (para.3-38).

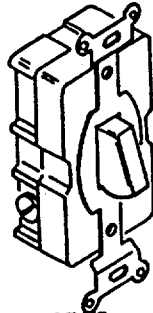

MODEL
TKR1200C

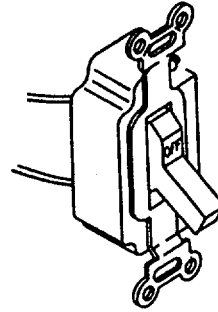

MODEL
REF 1200

PROCEDURE

1. Attach leads of Multimeter to switch terminals.
2. With switch set to OFF, check for continuity across switch. If there is continuity, switch is defective.
3. Set switch to ON and check for continuity. There must be continuity or switch is defective.
4. Set switch to OFF and verify that continuity is interrupted.

NOTE

FOLLOW-ON MAINTENANCE: Install switch (para. 3-38).

3-40. REMOVE/INSTALL THERMOMETER.

TOOLS: Screwdriver, Flat Tip

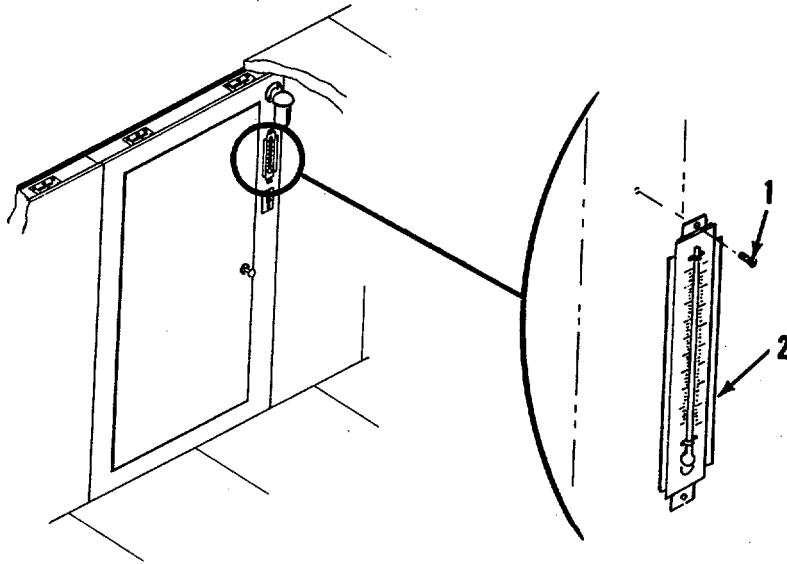

REMOVAL

1. Remove two screws (1) with screwdriver.
2. Remove thermometer (2).

INSTALLATION

1. Position thermometer (2) on door frame panel assembly.
2. Mount thermometer to door frame panel assembly interior using two screws (1).

3-41. REMOVE/INSTALL DOOR TRIMS (HEAD JAMB, SILL, LEFT AND RIGHT TRIMS).

TOOLS: Screwdriver, Cross Tip

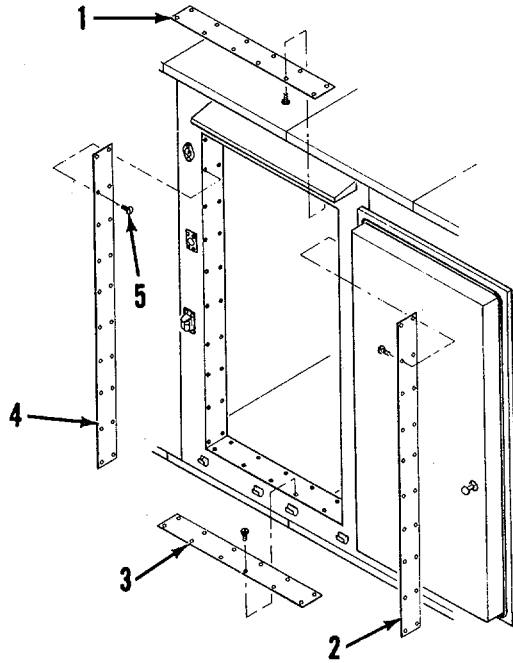

REMOVAL

1. Remove head jamb (1), right trim (2), sill (3), or left door trim (4) by removing screws (5) with screwdriver.

INSTALLATION

1. Position head jamb (1), right trim (2), sill (3), and left door trim (4) and secure in place with screws (5). Tighten screws with screwdriver.

3-42. REMOVE/INSTALL SPRING CLIPS AND HEX WRENCHES.

TOOLS: Screwdriver, Flat Tip

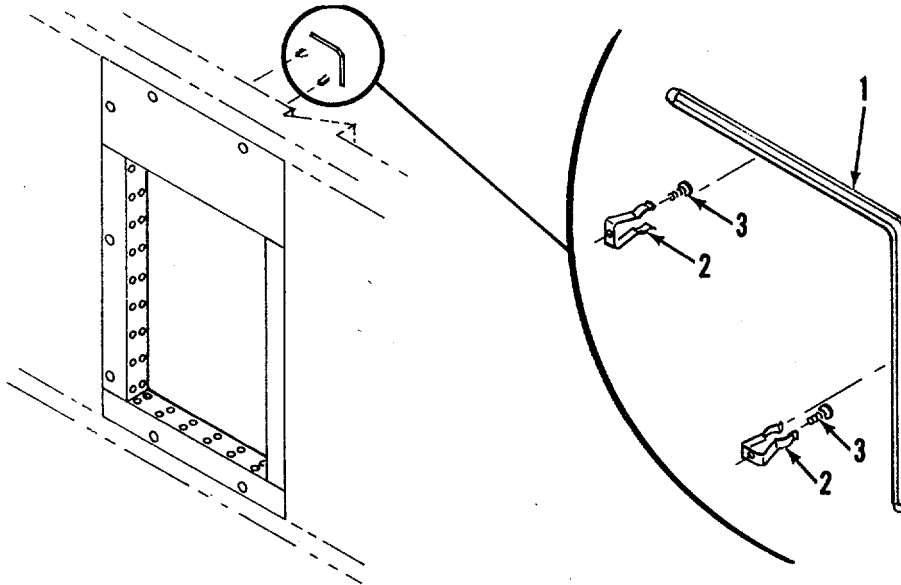

REMOVAL

1. Unsnap and remove hex wrench (1) from spring clips (2).
2. Using screwdriver, remove screws (3) and remove spring clips (2).

INSTALLATION

1. Attach spring clips (2) to evaporator panel assembly with screws (3). Tighten screws with screwdriver.
2. Snap replacement hex wrench (1) into spring clips (2).

3-43. REMOVE/INSTALL EVAPORATOR PANEL TRIM.

TOOLS: Screwdriver, Cross Tip

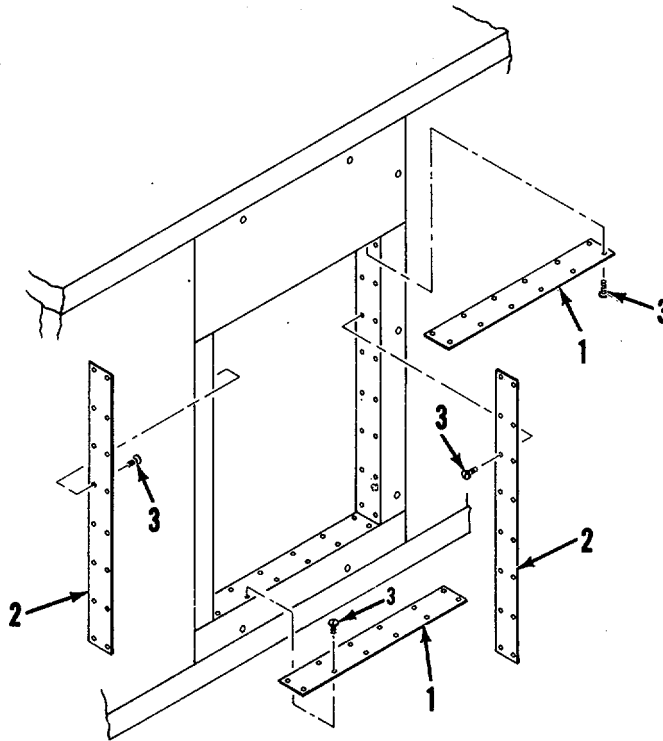

REMOVAL

1. Remove top and bottom trim (1), or left and right side trim (2) from evaporator panel assembly by removing screws (3).

INSTALLATION

1. Position trim (1 or 2) as applicable on evaporator panel assembly and secure in place with screws (3).

3-44. REPLACEMENT OF LEFT, CENTER, AND RIGHT FLOOR PANEL ASSEMBLIES (TYPICAL).

TOOLS: Hex Wrench

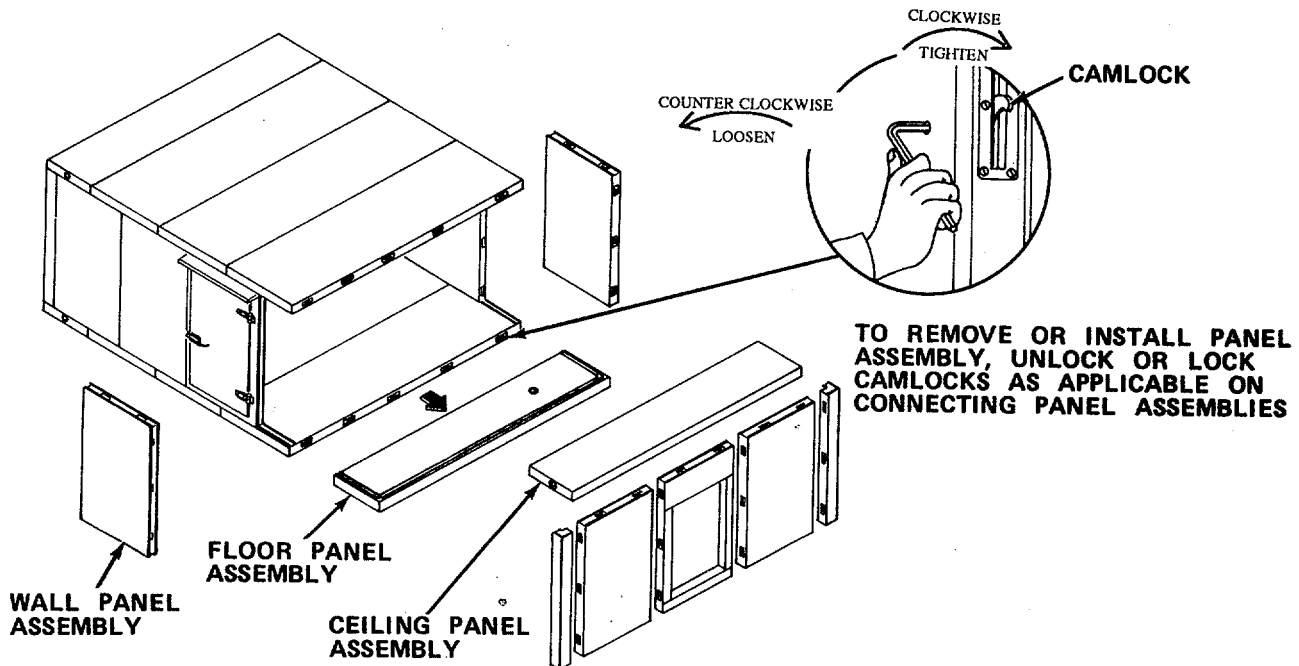

NOTE

Removal or installation of a floor panel assembly will require removal of applicable ceiling and wall panel assemblies supported by the floor section. Determine specific panel assemblies to be removed before proceeding.

REMOVAL

1. Unlock and remove ceiling panel assembly(s) as needed per para. 3-14.
2. Unlock and remove wall structure panel assemblies as needed per para. 3-29.
3. Unlock floor panel assembly from adjacent floor panel assembly(s) and remove.

INSTALLATION

1. Position replacement floor panel assembly and lock to adjacent floor panel assembly.
2. Reposition removed wall panel assemblies and lock to adjacent wall panel assemblies as applicable.
3. Lock floor ends of wall panel assemblies to connecting floor panel assembly(s).

4. Reinstall any removed ceiling panel assembly in accordance with para. 3-14. Lock ceiling endsof panel assemblies to the ceiling panel assemblies. Reapply tape (item 11, Appx E) over external ceiling and upper wall joints.

Section VII. PREPARATION FOR STORAGE OR SHIPMENT

3-45. PREPARATION FOR STORAGE.

- A. Empty refrigerator completely.
- B. Remove any auxiliary equipment, cooling unit, or other refrigeration equipment if needed in accordance with the manuals covering those items.
- C. If refrigeration equipment is removed, cover evaporator panel openings with tarp or other covering.
- D. Secure door with padlock and chain. Securely attach keys to padlock.
- E. If disassembly is required, perform paragraph 3-46 B, below.

3-46. PREPARATION FOR SHIPMENT.

A. GENERAL.

1. The refrigerator is shipped disassembled. Prior to disassembly, remove all contents and any auxiliary equipment.
2. Refer to the instructions below for dismantling the unit. Remove all breakable components in accordance with applicable instructions and pack separately. Tape padding over mounting holes vacated by removed components and drain and strainers. When removing panel assemblies, be sure all camlocks are fully rotated counterclockwise (retracted) to prevent damage.
3. Crate the components in original shipping crates, if available. For short distances, or if original shipping crates are not available, place the components in easily handled loads on skids. Place cushioning material and wooden spacers between surfaces that are easily damaged. Secure the skids with metal banding. Cushion separately packed components with cellulose wadding or other cushioning material. Pack the cushioned items with basic issue items in a suitable fiberboard container. Attach identification tags to or label all separately packed components.
4. The crated components of the refrigerator are shipped either by tractor-trailer or rail. Secure all crated components to the carrier bed with tie-down cables, strapping, blocking as needed. Refer to paragraph 3-6 for a typical shipping illustration.

1. Remove large and small floor rack assemblies from inside the refrigerator.

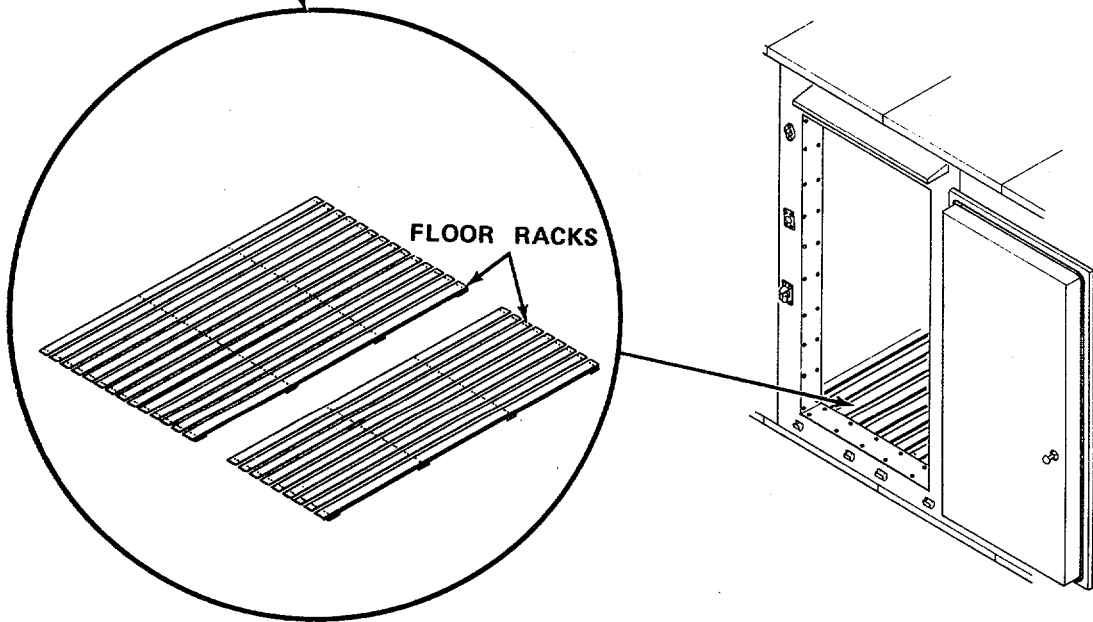

2. Turn off power supply and unplug female receptacle from unit. Remove power cord and female receptacle as needed and pack separately.

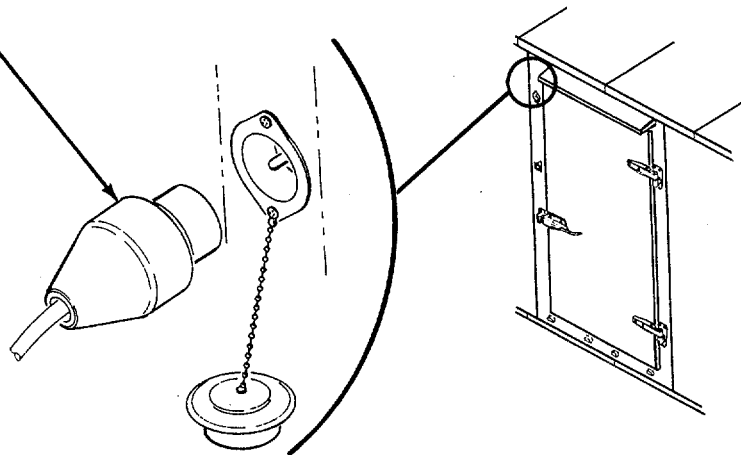

3. Tape padding over pilot light to prevent damage.

4. Remove plug from male receptacle.

5. Unthread globe and remove bulb from vapor proof light fixture.

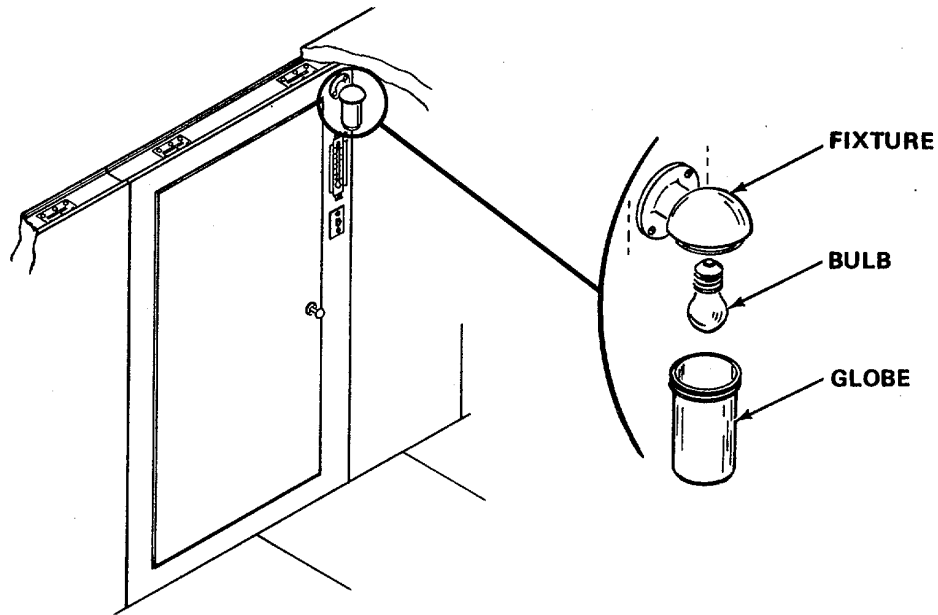

6. Remove two screws and remove thermometer.

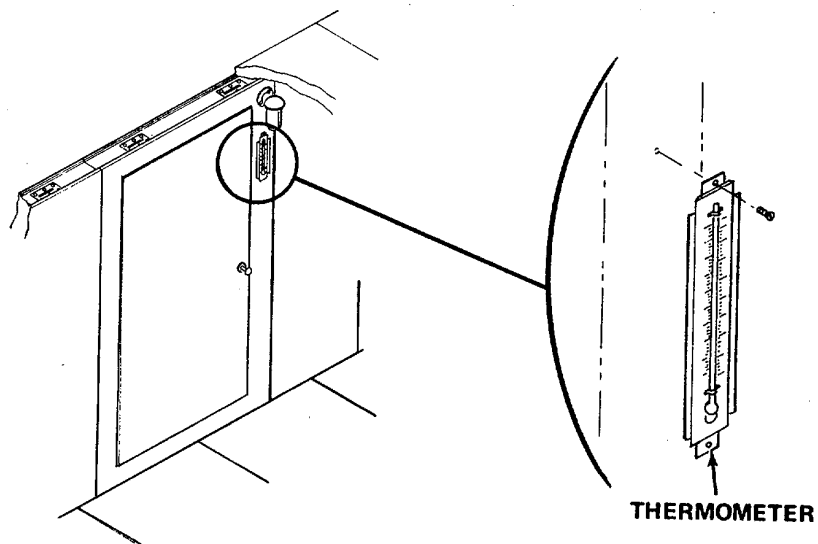

7. Remove sealing tape from all exterior ceiling joints between ceiling and wall structure panel assemblies.

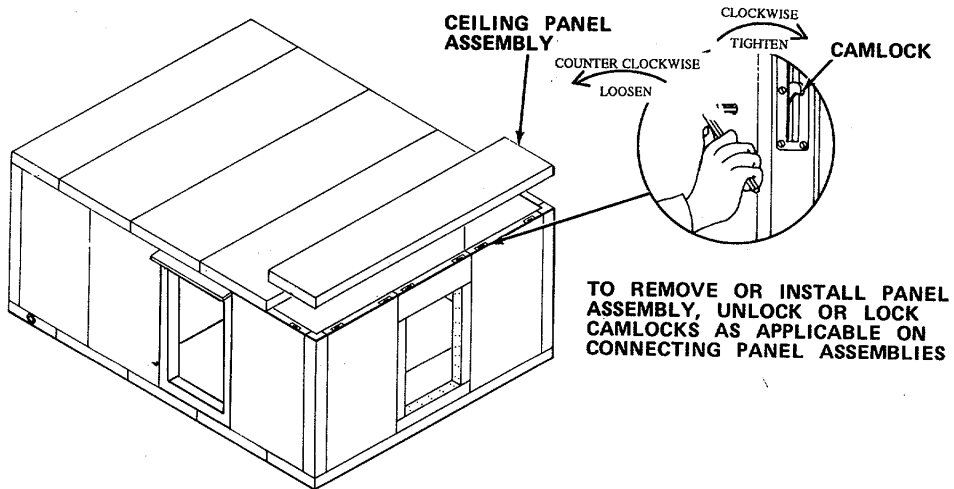

8. Unlock camlocks on ceiling ends of supporting wall structure panel assembly. Unlock camlocks on all ceiling panel assemblies beginning with right ceiling panel assembly; remove all ceiling panel assemblies.

9. Remove door canopy.

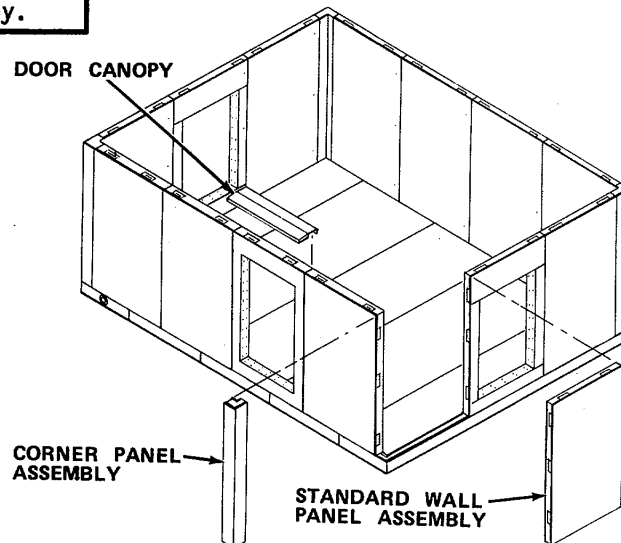

10. Unlock all wall structure panel assemblies from each other. Beginning with one corner panel assembly, unlock floor ends of wall panel assemblies. Remove wall panel assembly as soon as it is unlocked from the floor. Continue around refrigerator until all wall panel assemblies are removed.

11. Unlock floor panel assemblies from each other and remove.

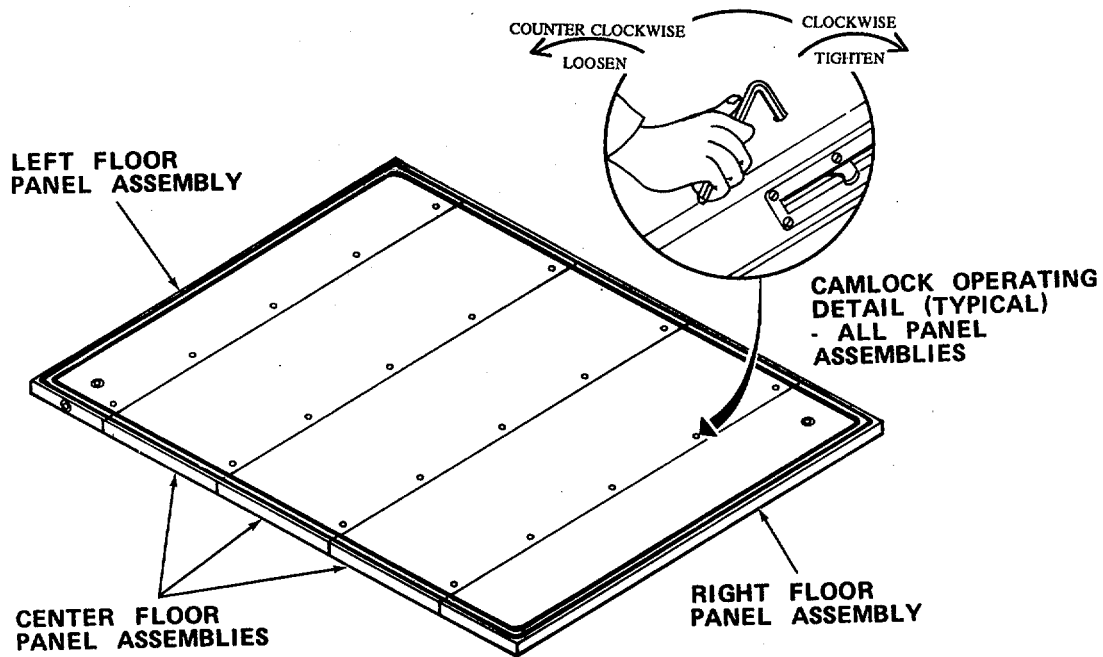

CHAPTER 4
DIRECT SUPPORT AND GENERAL SUPPORT MAINTENANCE INSTRUCTIONS

Section I. DIRECT SUPPORT AND GENERAL SUPPORT TROUBLESHOOTING

- 4-1.** This table lists malfunctions which may occur during operation or maintenance of the refrigerator or its components. The manual cannot list all malfunctions that may occur, nor all test and inspections or corrective action. If a malfunction is not listed or is not corrected by listed corrective actions, notify your supervisor. Only those checks and corrective actions authorized for direct support and general support maintenance are listed.

Malfunction
Test or Inspection
Corrective Action

REFRIGERATOR DOES NOT MAINTAIN DESIRED COOLING TEMPERATURE; UNSTABLE INTERNAL TEMPERATURE.

- Step 1. Check installed refrigeration equipment in accordance with its TM.
- Repair or Replace refrigeration cooling equipment as needed in accordance with its TM.
- Step 2. Check refrigerator walk-in door for proper closing and sealing at its gasket. Check for proper door latch operation.
- Replace door gasket per para. 3-28 if needed. Repair latch per para. 3-23 if necessary.
- Step 3. Inspect refrigerator ceiling, wall, and floor panel assemblies for cracks, holes, punctures on surfaces, and other structural damage.
- Repair refrigerator panels per para. 4-2, below. Replace entire panel assembly if framework is damaged.
- Step 4. Unstable internal temperatures or failure to maintain desired temperatures may be caused by damaged or deteriorated gasket panels. If needed, disassemble refrigerator per para. 3-48 and inspect all gasket panels for damage or deterioration.
- Replace gasket panels per para. 3-18.

Section II. DIRECT SUPPORT AND GENERAL SUPPORT MAINTENANCE PROCEDURES.

4-2. INITIAL SETUP.

TOOLS: Pocket Knife
Screwdriver, Flat Tip

SUPPLIES: Repair Kit MIL-2-58047(CE) or MIL-R-19907C
Sandpaper (item 1, Appx E)
Sealing Compound (item 9, Appx E)

4-3. REPAIR REFRIGERATOR PANELS (ALL PANELS).

1. Seal minor holes and punctures on panels with sealing compound (item 9, Appx E)

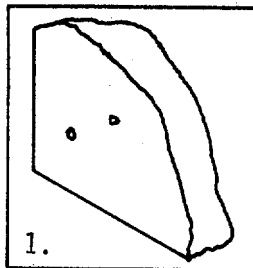

2. To repair minor rips and tears, use repair kit MIL-2-58047 or MIL-R-19907C Prior to repair, roughen metal surfaces around damaged area with sandpaper (item 1, Appx E) to remove paint and improve adhesion.

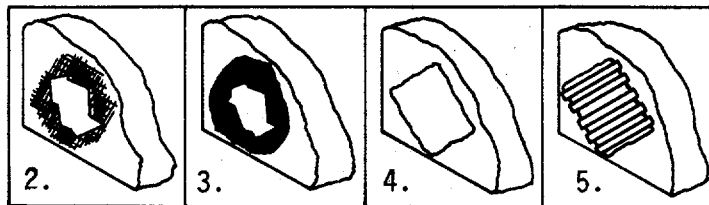

3. Apply a uniform layer of epoxy mixture from repair kit onto roughened surfaces around the damaged area
4. Cut patch material from repair kit enough to cover damaged area and epoxy mixture on panel. Press patch material over damaged area and epoxy mixture. Stretch out patch on all sides to ensure uniform adhesion.
5. Apply tape from repair kit over the entire patched area
6. For damaged areas up to 144 square inches (92,908 square mm) perform steps 2 through 5, above using the repair kit, but apply epoxy to cloth, nylon, or like material cut 2 to 3 inches (51 to 76 mm) greater in each direction of hole to be covered.
7. Affix patch over damaged area. Tape over patch in vertical and horizontal directions so that patch will not move while curing. Approximately 2 hours are required for patch to adhere properly.

**APPENDIX A
REFERENCES**

A-1. SCOPE.

This appendix lists all forms, field manuals, technical manuals, and miscellaneous publications referenced to in this manual.

A-2. FORMS

Equipment Inspection and Maintenance Worksheet.....	DA Form 2404
Packaging Improvement Report.....	DD Form 6
Recommended Changes to DA Publications	DA Form 2028-2
Recommended Changes to Publications and Blank Forms.....	DA Form 2028

A-3. FIELD MANUALS.

First Aid for Soldiers.....	FM 21-11
-----------------------------	----------

A-4. TECHNICAL MANUALS.

Destruction of Army Materiel to Prevent Enemy Use	TM 750-244-3
The Army Maintenance Management System (TAMMS)	DA Pam 738-750
Repair Parts and Special Tools List, Refrigerator, Prefabricated, (1200 Cubic Foot) Model TKR 1200C, NSN 4110-01-239-9200 and Model REF 1200, NSN 4110-01-315-9330.....	TM 9-4110-246-24P

A-5. MISCELLANEOUS PUBLICATIONS.

Abbreviations for Use on Drawings and Specifications.....	MIL-STD-12
Expendable/Durable Items (Except: Medical, Class V, Repair Parts, and Heraldic Items)	CTA50-970
Federal Supply Code for Manufacturers, US and Canada	SB 708-42

APPENDIX B

MAINTENANCE ALLOCATION CHART (MAC)

Section I. INTRODUCTION

B-1. The Army Maintenance System MAC

This introduction provides a general explanation of all maintenance and repair functions authorized at the two maintenance levels under the Two-Level Maintenance System concept.

This MAC (immediately following the introduction) designates overall authority and responsibility for the performance of maintenance functions on the identified end item or component. The application of the maintenance functions to the end item or component shall be consistent with the capacities and capabilities of the designated maintenance levels, which are shown on the MAC in column (4) as:

Field - includes two columns, Unit maintenance and Direct Support maintenance. The Unit maintenance column is divided again into two more subcolumns, C for Operator or Crew and O for Unit maintenance.

Sustainment – includes two subcolumns, General Support (H) and Depot (D).

The tools and test equipment requirements (immediately following the MAC) list the tools and test equipment (both special tools and common tool sets) required for each maintenance function as referenced from the MAC.

The remarks (immediately following the tools and test equipment requirements) contain supplemental instructions and explanatory notes for a particular maintenance function.

B-2. Maintenance Functions

Maintenance functions are limited to and defined as follows:

1. Inspect. To determine the serviceability of an item by comparing its physical, mechanical, and/or electrical characteristics with established standards through examination (e.g., by sight, sound, or feel.) This includes scheduled inspection and gagings and evaluation of cannon tubes.
2. Test. To verify serviceability by measuring the mechanical, pneumatic, hydraulic, or electrical characteristics of an item and comparing those characteristics with prescribed standards on a scheduled basis, i.e., load testing of lift devices and hydrostatic testing of pressure hoses.
3. Service. Operations required periodically to keep an item in proper operating condition; e.g., to clean (includes decontaminate, when required), to preserve, to drain, to paint, or to replenish fuel, lubricants, chemical fluids, or gases. This includes scheduled exercising and purging of recoil mechanisms. The following are examples of service functions:
 - a. Unpack. To remove from packing box for service or when required for the performance of maintenance operations.
 - b. Repack. To return item to packing box after service and other maintenance operations.
 - c. Clean. To rid the item of contamination.

- d. Touch up. To spot paint scratched or blistered surfaces.
 - e. Mark. To restore obliterated identification.
4. Adjust. To maintain or regulate, within prescribed limits, by bringing into proper position, or by setting the operating characteristics to specified parameters.
 5. Align. To adjust specified variable elements of an item to bring about optimum or desired performance
 6. Calibrate. To determine and cause corrections to be made or to be adjusted on instruments of test, measuring, and diagnostic equipment used in precision measurement. Consists of comparisons of two instruments, one of which is a certified standard of known accuracy, to detect and adjust any discrepancy in the accuracy of the instrument being compared.
 7. Remove/Install. To remove and install the same item when required to perform service or other maintenance functions. Install may be the act of emplacing, seating, or fixing into position a spare, repair part, or module (component or assembly) in a manner to allow the proper functioning of an equipment or system.
 8. Paint. To prepare and spray color coats of paint so that the ammunition can be identified and protected. The color indicating primary use is applied, preferably, to the entire exterior surface as the background color of the item. Other markings are to be repainted as original so as to retain proper ammunition identification.
 9. Replace. To remove an unserviceable item and install a serviceable counterpart in its place. "Replace" is authorized by the MAC and assigned maintenance level is shown as the third position code of the Source, Maintenance and Recoverability (SMR) code.
 10. Repair. The application of maintenance services, including fault location/troubleshooting, removal/installation, disassembly/assembly procedures and maintenance actions to identify troubles and restore serviceability to an item by correcting specific damage, fault, malfunction, or failure in a part, subassembly, module (component or assembly), end item, or system.

NOTE

The following definitions are applicable to the "repair" maintenance function:

Services. Inspect, test, service, adjust, align, calibrate, and/or replace.

Fault location/troubleshooting. The process of investigating and detecting the cause of equipment malfunctioning; the act of isolating a fault within a system or Unit Under Test (UUT).

Disassembly/assembly. The step-by-step breakdown (taking apart) of a spare/functional group coded item to the level of its least component, that is assigned an SMR code for the level of maintenance under consideration (i.e., identified as maintenance significant).

Actions. Welding, grinding, riveting, straightening, facing, machining, and/or resurfacing.

11. Overhaul. That maintenance effort (service/action) prescribed to restore an item to a completely serviceable/operational condition as required by maintenance standards in appropriate technical publications. Overhaul is normally the highest degree of maintenance performed by the Army. Overhaul does not normally return an item to like new condition.
12. Rebuild. Consists of those services/actions necessary for the restoration of unserviceable equipment to a like new condition in accordance with original manufacturing standards. Rebuild is the highest degree of material maintenance applied to Army equipment. The rebuild operation includes the act of returning to zero those age measurements (e.g., hours/miles.) considered in classifying Army equipment/components.

B-3. Explanation of Columns in the MAC, Section II

Column (1) Group Number. Column (1) lists Functional Group Code (FGC) numbers, the purpose of which is to identify maintenance significant components, assemblies, subassemblies, and modules with the Next Higher Assembly (NHA).

Column (2) Component/Assembly. Column (2) contains the names of components, assemblies, subassemblies, and modules for which maintenance is authorized.

Column (3) Maintenance Function. Column (3) lists the functions to be performed on the item listed in column (2). (For a detailed explanation of these functions refer to "Maintenance Functions" outlined above).

Column (4) Maintenance Level. Column (4) specifies each level of maintenance authorized to perform each function listed in column (3), by indicating work time required (expressed as manhours in whole hours or decimals) in the appropriate subcolumn. This work time figure represents the active time required to perform that maintenance function at the indicated level of maintenance. If the number or complexity of the tasks within the listed maintenance function varies at different maintenance levels, appropriate work time figures are to be shown for each level. The work time figure represents the average time required to restore an item (assembly, subassembly, component, module, end item, or system) to a serviceable condition under typical field operating conditions. This time includes preparation time (including any necessary disassembly/assembly time), troubleshooting/fault location time, and quality assurance time in addition to the time required to perform the specific tasks identified for the maintenance functions authorized in the MAC. The system designations for the various maintenance levels are as follows:

Field:

- C Operator or Crew maintenance
- O Unit maintenance
- F Direct Support maintenance

Sustainment:

- L Specialized Repair Activity
- H General Support maintenance
- D Depot maintenance

NOTE

The "L" maintenance level is not included in column (4) of the MAC. Functions to this level of maintenance are identified by work time figure in the "H" column of column (4), and an associated reference code is used in the REMARKS column (6). This code is keyed to the remarks and the SRA complete repair application is explained there.

Column (5) Tools and Equipment Reference Code. Column (5) specifies, by code, those common tool sets (not individual tools), common Test, Measurement and Diagnostic Equipment (TMDE), and special tools, special TMDE and special support equipment required to perform the designated function. Codes are keyed to the entries in the tools and test equipment table.

Column (6) Remarks Code. When applicable, this column contains a letter code, in alphabetic order, which is keyed to the remarks table entries.

B-4. Explanation of Columns in the Tools and Test Equipment Requirements, Section III

Column (1) - Tool or Test Equipment Reference Code. The tool or test equipment reference code correlates with a code used in column (5) of the MAC.

Column (2) - Maintenance Level. The lowest level of maintenance authorized to use the tool or test equipment.

Column (3) - Nomenclature. Name or identification of tool or test equipment.

Column (4) - National Stock Number (NSN). The NSN of the tool or test equipment.

Column (5) - Tool Number. The manufacturer's part number.

B-5. Explanation of Columns in Remarks, Section IV

Column (1) - Remarks Code. The code recorded in Column (6) of the MAC.

Column (2) - Remarks. This column lists information pertinent to the maintenance function being performed as indicated in the MAC.

**Section II. MAINTENANCE ALLOCATION CHART
FOR REFRIGERATOR, PREFABRICATED**

(1) GROUP NUMBER	(2) COMPONENT/ ASSEMBLY	(3) MAINTENANCE FUNCTION	(4) MAINTENANCE LEVEL					(5) TOOLS AND EQUIPMENT REFERENCE CODE	(6) REMARKS CODE	
			FIELD		SUSTAINMENT					
			UNIT		DIRECT SUPPORT	GENERAL SUPPORT	DEPOT			
			C	O	F	H	D			
00	REFRIGERATOR PREFAVRICATED									
01	RIGHT CEILING PANEL ASSEMBLY	Inspect Service Replace	0.1	0.1 2.0						
	STRAINER	Inspect Service Replace	0.1 0.1	0.2						
	OUTSIDE DRAIN	Inspect Service Replace	0.1 0.1	0.2						
	GASKET PANEL	Inspect Replace		0.2 1.5						
	RIGHT CEILING PANEL	Inspect Service Repair	0.1 0.1		2.5					
02	CENTER CEILING PANEL ASSEMBLY	Inspect Service Replace	0.1	0.1 2.5						
	GASKET PANEL	Inspect Replace		0.2 1.5						
	CAMLOCK	Inspect Replace		0.2 0.5						
	CENTER CEILING PANEL	Repair			2.5					
03	LEFT CEILING PANEL ASSEMBLY	Inspect Service Replace	0.1 0.1		2.0					
	STRAINER	Inspect Service Replace	0.1 0.1	0.2						
	OUTSIDE DRAIN	Inspect Service Replace	0.1 0.1	0.2						
	GASKET PANEL	Inspect Replace		0.2 1.5						
	CAMLOCK	Inspect Replace		0.2 0.5						
	LEFT CEILING PANEL	Repair			2.5					
04	DOOR CANOPY	Inspect Replace	0.1	2.1						

**Section II. MAINTENANCE ALLOCATION CHART
FOR REFRIGERATOR, PREFABRICATED - continued**

(1) GROUP NUMBER	(2) COMPONENT/ ASSEMBLY	(3) MAINTENANCE FUNCTION	(4) MAINTENANCE LEVEL					(5) TOOLS AND EQUIPMENT REFERENCE CODE	(6) REMARKS CODE
			FIELD		SUSTAINMENT				
			UNIT		DIRECT SUPPORT	GENERAL SUPPORT	DEPOT		
			C	O	F	H	D		
05	WALK IN DOOR ASSEMBLY	Inspect	0.1						
		Service	0.2						
		Replace		1.5					
	PADLOCK AND CHAIN	Inspect	0.1						
		Replace		0.2					
	LATCH AND STRIKE ASSEMBLY	Inspect	0.2						
		Service	0.1						
		Repair Replace		0.5 1.0					
HINGES	Inspect	0.1							
	Service Replace	0.1		1.5					
DOOR GASKET	Inspect	0.1							
	Replace		0.5						
DECALMANIA	Inspect	0.1							
	Replace		0.4						
	WALK IN DOOR PANEL	Repair			2.5				
06	DOOR FRAME PANEL ASSEMBLY	Inspect	0.1						
		Service	0.1						
		Replace		2.8					
	FEMALE RECEPTACLE	Inspect	0.3						
		Test Replace		0.3 0.5			1		
	BOOT	Inspect	0.1						
		Replace		0.6					
	COVER, PILOT LIGHT	Inspect	0.1						
		Service Replace	0.1		0.2				
	PILOT LIGHT HOUSING ASSEMBLY	Inspect	0.3						
Test Replace			0.2 0.5			1			
CAP AND CHAIN	Inspect	0.1							
	Replace		0.1						
MALE RECEPTACLE	Inspect	0.1							
	Test Replace		0.2 0.5			1			
VAPOR PROOF LIGHT FIXTURE	Inspect	0.1							
	Service	0.1							
	Test Replace		0.3 0.6						
SWITCH COVER	Inspect	0.1							
	Service Replace	0.1		0.2					

**Section II. MAINTENANCE ALLOCATION CHART
FOR REFRIGERATOR, PREFABRICATED - continued**

(1) GROUP NUMBER	(2) COMPONENT/ ASSEMBLY	(3) MAINTENANCE FUNCTION	(4) MAINTENANCE LEVEL					(5) TOOLS AND EQUIPMENT REFERENCE CODE	(6) REMARKS CODE
			FIELD		SUSTAINMENT				
			UNIT		DIRECT SUPPORT	GENERAL SUPPORT	DEPOT		
			C	O	F	H	D		
07	SWITCH	Inspect Test Replace	0.2	0.2 0.5				1	
	THERMOMETER	Inspect Replace	0.1	0.2					
	HEAD JAMB	Inspect Replace	0.1	0.5					
	DOOR JAMB (LEFT AND RIGHT)	Inspect Replace	0.1	0.5					
	SILL	Inspect Replace	0.1	0.5					
	GASKET PANEL	Inspect Replace		0.2 1.5					
	CAMLOCK	Inspect Replace		0.2 0.5					
	DOOR FRAME PANEL	Repair			2.5				
	EVAPORATOR PANEL ASSEMBLY	Inspect Service Replace	0.1 0.1	2.5					
	SPRING CLIPS	Inspect Replace	0.1	0.2					
	HEX WRENCH	Inspect Replace	0.1	0.1					
	SIDE TRIM	Inspect Replace	0.1	0.5					
	TOP AND BOTTOM TRIM	Inspect Replace	0.1	0.5					
	GASKET PANEL	Inspect Replace		0.2 1.5					
08	CAMLOCK	Inspect Replace		0.2 0.5					
	EVAPORATOR PANEL	Repair			2.5				
	STANDARD WALL PANEL ASSEMBLY	Inspect Service Replace	0.1 0.1	2.5					
	GASKET PANEL	Inspect Replace		0.2 1.5					
	CAMLOCK	Inspect Replace		0.2 1.5					

**Section II. MAINTENANCE ALLOCATION CHART
FOR REFRIGERATOR, PREFABRICATED - continued**

(1) GROUP NUMBER	(2) COMPONENT/ ASSEMBLY	(3) MAINTENANCE FUNCTION	(4) MAINTENANCE LEVEL					(5) TOOLS AND EQUIPMENT REFERENCE CODE	(6) REMARKS CODE
			FIELD			SUSTAINMENT			
			UNIT		DIRECT SUPPORT	GENERAL SUPPORT	DEPOT		
			C	O	F	H	D		
09	STANDARD WALL PANEL	Repair			2.5				
	CORNER PANEL ASSEMBLY	Inspect	0.1						
		Service	0.1						
		Replace		2.0					
10	GASKET PANEL	Inspect		0.2					
		Replace		1.5					
	CAMLOCK	Inspect		0.2					
		Replace		0.5					
11	CORNER PANEL	Repair			2.5				
	RIGHT FLOOR PANEL ASSEMBLY	Inspect	0.1						
		Service	0.1						
		Replace		3.0					
12	STRAINER	Inspect	0.1						
		Service	0.1						
	Replace		0.2						
	OUTSIDE DRAIN	Inspect	0.1						
11	GASKET PANEL	Service	0.1						
		Replace		0.2					
	RIGHT FLOOR PANEL	Inspect		0.2					
		Replace		1.5					
11	CENTER FLOOR PANEL ASSEMBLY	Repair			2.5				
		Inspect	0.1						
		Service	0.1						
	Replace		4.0						
12	GASKET PANEL	Inspect		0.2					
		Replace		1.5					
	CAMLOCK	Inspect		0.2					
		Replace		0.5					
12	CENTER FLOOR PANEL	Repair			2.5				
	LEFT FLOOR PANEL ASSEMBLY	Inspect	0.1						
		Service	0.1						
		Replace		3.0					
12	STRAINER	Inspect	0.1						
		Service	0.1						
	Replace		0.2						
12	OUTSIDE DRAIN	Inspect	0.1						
		Service	0.1						
		Replace		0.2					

**Section II. MAINTENANCE ALLOCATION CHART
FOR REFRIGERATOR, PREFABRICATED - continued**

(1) GROUP NUMBER	(2) COMPONENT/ ASSEMBLY	(3) MAINTENANCE FUNCTION	(4) MAINTENANCE LEVEL					(5) TOOLS AND EQUIPMENT REFERENCE CODE	(6) REMARKS CODE
			FIELD			SUSTAINMENT			
			UNIT		DIRECT SUPPORT	GENERAL SUPPORT	DEPOT		
			C	O	F	H	D		
13	GASKET PANEL	Inspect Replace		0.2 1.5					
	CAMLOCKS	Inspect Replace		0.2 0.5					
	LEFT FLOOR PANEL	Repair			2.5				
	FLOOR RACKS LARGE AND SMALL	Inspect Service	0.2	0.5					

**Section III. TOOLS AND TEST EQUIPMENT
FOR REFRIGERATOR, PREFABRICATED**

(1) TOOL OR TEST EQUIPMENT REFERENCE CODE	(2) MAINTENANCE LEVEL	(3) NOMENCLATURE	(4) NATIONAL STOCK NUMBER	(5) TOOL NUMBER
1	0	Digital Multimeter AN/PSM-45	6625-01-139-2512	

**Section IV. REMARKS
FOR REFRIGERATOR, PREFABRICATED**

(1) REMARKS CODE	(2) REMARKS

APPENDIX C
COMPONENTS OF END ITEM AND BASIC ISSUE ITEMS LISTS

Section I. INTRODUCTION

C-1. SCOPE.

This appendix lists components of end item and basic issue items for the refrigerator to help you inventory items required for safe and efficient operation.

C-2 GENERAL.

The Component of End Item and Basic Issue Items Lists are divided into the following sections:

a. Section II. Components of End Item. This listing is for informational purposes only, and is not authority to requisition replacements. These items are part of the end item, but are removed and separately packaged for transportation or shipment. As part of the end item, these items must be with the item whenever it is issued or transferred between property accounts. Illustrations are furnished to assist you in identifying the items.

b. Section III. Basic Issue Items. These are the minimum essential items required to place the refrigerator in operation, to operate it, and to perform emergency repairs. Although shipped separately packaged, BII must be with the refrigerator during operation and whenever it is transferred between property accounts. The illustrations will assist you with hard-to-identify items. This manual is your authority to request/requisition replacement BII, based on TOE/MTOE authorization of the end item.

C-3 EXPLANATION OF COLUMNS.

The following provides an explanation of columns found in the tabular listings.

a. Column (1)-Illustration Number (Illus Number). This column indicates the number of the illustration in which the item is shown.

b. Column (2)-National Stock Number. Indicates the National stock number assigned to the item and will be used for requisitioning purposes.

c. Column (3)-Description. Indicates the Federal item name and, if required, a minimum description to identify and locate the item. The last line for each item indicates the FSCM (in parentheses) followed by the part number.

d. Column (4)-Unit of Measure (U/M). Indicates the measure used in performing the actual operation/maintenance function. This measure is expressed by a two-character alphabetical abbreviation (e.g., ea, in, pr).

e. Column (5)-Quantity required (Qty rqr). Indicates the quantity of the item authorized to be used with/on the equipment.

Section II. BASIC ISSUE ITEMS

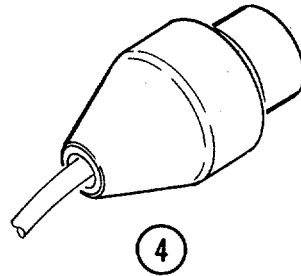
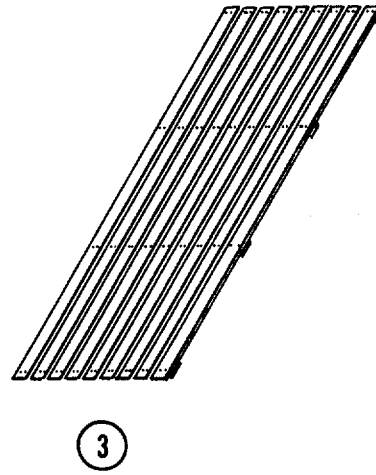
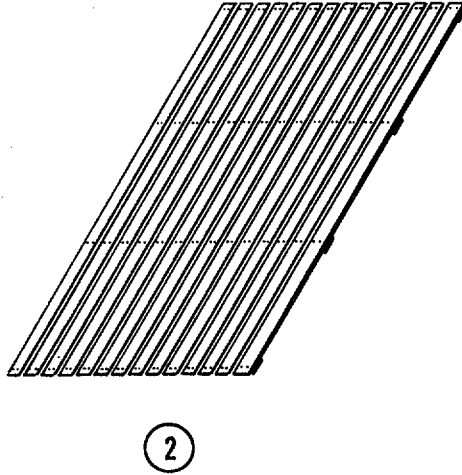
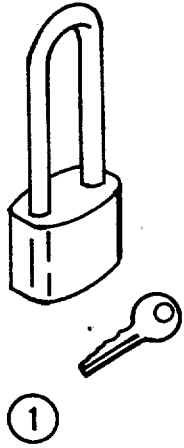

(1) Illus Number	(2) National Stock Number	(3) Description FSCM and Part Number	(4) UM	(5) Qty Rqr
1		PADLOCK AND KEY (53853) 4882	Set	1
2		FLOOR RACK, LARGE (53853) 9915G	EA	6
3		FLOOR RACK, SMALL (53853) 9914G	EA	4
4		FEMALE RECEPTACLE AND BOOT mounted on power supply cord (74545) 7484 and 7440	Ea	1

APPENDIX D
ADDITIONAL AUTHORIZATION LIST

NOT APPLICABLE

D-1/(D-2 blank)

APPENDIX E

EXPENDABLE/DURABLE SUPPLIES AND MATERIALS LIST

Section I. INTRODUCTION

E-1. SCOPE. This appendix lists expendable/durable supplies and materials you will need to operate and maintain the refrigerator. These items are authorized to you by CTA 50-970, maintain the refrigerator. These items are authorized to you by CTA 50-970, Expendable Items (Except Medical, Class V, Repair Parts, and Heraldic Items).

E-2 EXPLANATION OF COLUMNS.

a. Column (1)-Item number. This number is assigned to the entry in the listing and is referenced in the narrative instructions to identify the material (e.g., " Use baking soda, item 2, App E).

b. Column (2)-Level. This column identifies lowest level of maintenance that requires the listed item. (enter as applicable)

C-Operator/Crew
O-Unit Maintenance
F-Direct Support Maintenance
H-General Support Maintenance

c. Column (3)-National Stock Number. This is the National Stock number assigned to the item; use it to request or requisition the item.

d. Column (4)-Description. Indicates the Federal item name and, if required, a description to identify the item. The last line for each item indicates the Federal Supply Code for Manufacturer (FSCM) in parentheses followed by the part number.

e. Column (5)-Unit of Measure (U/M). Indicates the measure used in performing the actual maintenance function. This measure is expressed by a two-character alphabetical abbreviation (e.g., ea, in, pr). If the unit of measure differs from the unit of issue, requisition the lowest unit of issue that will satisfy your requirements.

Section II. EXPENDABLE/DURABLE SUPPLIES AND MATERIALS LIST

(1) ITEM NUMBER	(2) LEVEL	(3) NATIONAL STOCK NUMBER	(4) DESCRIPTION	(5) U/M
1	H	5360-00-224-7208	Sandpaper (81348) PP101	EA
2	C	8950-00-202-9611	Baking Soda	LB
3	O	8030-00-255-4447	Corrosion Preventive Compound (81349) MIL-C-22235	
4	O	3150-00-985-7316	Grease, GP (81349) MIL-G-23549	EA
5	O	9150-00-231-9045	Oil, Lubricating Low Viscosity (81348) VV-C-820	LIT
6	H	2090-00-372-6064	Repair Kit (81349) MIL-R-19907	EA
7	O	8030-00-231-2344	Rust Arresting Compound (81349) MIL-R-10036	LB
8	O		Rust Retarding Compound MIL-C-23050	LB
9	H	8030-00-965-2397	Sealing Compound (81348) TT-S-230	LB
10	C	6850-00-264-9038	Solvent, PD-680, Type 2	LIT
11	O	7510-01-017-6140	Tape, 4-Inch (81348) PIP-T-60, Type IV	EA

SUBJECT INDEX

<p>Subj/Para</p> <p style="text-align: center;">A</p> <p>Additional Authorization List,Appx D</p> <p>Assembly and Preparation for Use, 2-3</p> <p>Assembly of Equipment, 3-7</p> <p style="text-align: center;">B</p> <p style="text-align: center;">C</p> <p>Camlock, Inspect 3-19</p> <p>Camlock, Remove/Install, 3-2C</p> <p>Canopy Door, Replacement, 3-14</p> <p>Ceiling Panel Assemblies, Right Center and Left, Replacement of, 3-14</p> <p>Checking Unpacked Equipment, 3-6</p> <p>Common Tools and Equipment, 3-2</p> <p>Components and End Item ant Basic Issue Item Lists,Appx. C</p> <p>Controls and Indicators, 2-1</p> <p style="text-align: center;">D</p> <p>Decalmania, Remove/Install, 3-28</p> <p>Destruction of Army Materiel to Prevent Enemy Use, 1-3</p> <p>Direct Support Maintenance procedures 4-2</p> <p>Disassembly, 3-46</p> <p>Door Gasket, Remove/Install, 3-27</p> <p>Door Trim, Remove/Install, 3-41</p> <p style="text-align: center;">E</p> <p>Electrical Wiring, 3-8</p> <p>Equipment Data, 1-7</p> <p>Equipment Characteristics, Capabilities Subj/Para and Features, 1-5</p> <p>Evaporator Panel Trim, Remove/Install, 3-43</p> <p>Expendable/Durable Supplies and Materiels List,Appx. .E</p>	<p>Subj/Para</p> <p style="text-align: center;">F</p> <p>Female Receptacle: Remove/Install, 3-30</p> <p>Test, 3-31</p> <p>Floor Panel Assemblies, Left, Center and Right, Replacement of, 3-44</p> <p style="text-align: center;">G</p> <p>Gasket Door, Remove/Install, 3-27</p> <p>Gasket Panels: Inspect, 3-17</p> <p>Remove/install, 3-18</p> <p>General Support Maintenance Procedures 4-2</p> <p style="text-align: center;">H</p> <p>Hex Wrenches (Spring Clips), Remove/Install, 3-42</p> <p>Hinge, Remove/Install, 3-26</p> <p style="text-align: center;">I</p> <p>Installation Instructions, 3-7</p> <p style="text-align: center;">L</p> <p>Latch, Repair, 3-23</p> <p>Latch, Remove/Install, 3-25</p> <p>Latch Strike, Remove/Install, 3-24</p> <p>Location and Description of Major Components, 1-6</p> <p>Lubrication Instructions, 3-1</p>
--	---

SUBJECT INDEX

Subj/Para

M

Maintenance Allocation Chart (MAC), . Appx. B
Maintenance forms and Records,1-2
Maintenance Procedures,
 Direct Support,4-2
Maintenance Procedures, Unit,3-12
Male Receptacle:
 Remove/Install,3-34
 Test,3-34

O

Operating Instructions on Decals
 and Instruction Plates,2-6
Operating Procedures,2-4
Operation Under Unusual Conditions,2-7
 Operation in Salt-Water Areas,2-8
 Operation Under Rainy or Humid
 Conditions,2-7
Outside Drain, Remove/Install,3-16

P

Padlock and Chain, Remove/Install,3-22
Pilot Light Cover and Pilot Light Housing
 Assembly, Remove/Install,3-32
Pilot Light Housing Assembly, Test,3-33
Preliminary Servicing and Adjustment
 of Equipment,3-9
Preparation for Movement,2-5
Preparation for Shipment,3-46
Preparation for Storage,3-45
Preventive Maintenance Checks and
Services (PMCS), Operator,2-2
Preventive Maintenance Checks and
 Services (PMCS), Unit,3-10
Principles of Operation, Technical,
Procedures, Summary,3-13
Procedures, Unit Maintenance,3-12

R

References,..... Appx. A

Subj/Para

Refrigerator Panels, Repair,4-3
Reporting Equipment Improvement
 Recommendations,1-4

Replacement, Right, Center, and Left
 Ceiling Panel Assemblies and
 Door Canopy, 3-14

S

Scope, 1-1
Service, Upon Receipt of Equipment, 3-6
Site and Shelter Requirements, 3-5
Special Tools, TMDE and Support
 Equipment, 3-3
Spring Clips (and Hex Wrenches),
 Remove/Install, 3-42
Strainer, Remove/Install, 3-15
Summary Procedure, 3-13
Switch and Switch Cover,
 Remove/Install, 3-38
Switch, Test, 3-39

T

Technical Principles of Operation,
Thermometer, Remove/Install, 3-40
Tools and Test Equipment
 Requirement..... Appx. B
Troubleshooting, Direct
 Support and General
 Support 4-1
Troubleshooting, Unit, 3-11

U

V

Vapor Proof Light Fixture,
 Remove/Install, 3-36
 Test, 3-37

W

Wall Structure Panel, Assemblies
(Corner, Standard, Evaporator,
and Door Frame Panel),
Replacement, 3-29
Walk-in Door Assembly,
Remove/Install, 3-21
Wiring, Electrical, 3-8

By Order of the Secretaries of the Army and Air Force:

GORDON R SULLIVAN
General, United States Army
Chief of Staff

Official:

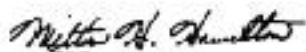

MILTON H HAMILTON
Administrative Assistant to the
Secretary of the Army

01695

MERRILL A. McPEAK
General USAF
Chief of Staff

Official:

EDWARD A. PARDINI, Colonel, USAF
Director of Information Management

DISTRIBUTION:

To be distributed in accordance with DA Form 12-25E, (qty rqr block no 4320)

These are the instructions for sending an electronic 2028

The following format must be used if submitting an electronic 2028. The subject line must be exactly the same and all fields must be included; however only the following fields are mandatory: 1, 3, 4, 5, 6, 7, 8, 9, 10, 13, 15, 16, 17, and 27.

From: "Whomever" <whomever@avma27.army.mil>
To: amssbriml@natick.army.mil

Subject: DA Form 2028

1. From: Joe Smith
2. Unit: home
3. Address: 4300 Park
4. City: Hometown
5. St: MO
6. Zip: 77777
7. Date Sent: 19-OCT-93
8. Pub no: 55-2840-229-23
9. Pub Title: TM
10. Publication Date: 04-JUL-85
11. Change Number: 7
12. Submitter Rank: MSG
13. Submitter FName: Joe
14. Submitter MName: T
15. Submitter LName: Smith
16. Submitter Phone: 123-123-1234
17. Problem: 1
18. Page: 2
19. Paragraph: 3
20. Line: 4
21. NSN: 5
22. Reference: 6
23. Figure: 7
24. Table: 8
25. Item: 9
26. Total: 123
27. Text:

This is the text for the problem below line 27.

RECOMMENDED CHANGES TO PUBLICATIONS AND BLANK FORMS For use of this form, see AR 25-30; the proponent agency is ODISC4.						Use Part II (reverse) for Repair Parts and Special Tool Lists (RPSTL) and Supply Catalogs/Supply Manuals (SC/SM).	DATE 21 October 2003
TO: (Forward to proponent of publication or form) (Include ZIP Code) COMMANDER U.S. ARMY TANK-AUTOMOTIVE AND ARMAMENT COMMAND ATTN: AMSTA-LC-CECT 15 KANSAS STREET NATICK, MA 01760-5052						FROM: (Activity and location) (Include ZIP Code) <i>PFC Jane Doe</i> <i>CO A 3rd Engineer BR</i> <i>Ft. Leonardwood, MO 63108</i>	
PART I – ALL PUBLICATIONS (EXCEPT RPSTL AND SC/SM) AND BLANK FORMS							
PUBLICATION/FORM NUMBER TM 10-1670-296-23&P				DATE 30 October 2002	TITLE Unit Manual for Ancillary Equipment for Low Velocity Air Drop Systems		
ITEM NO.	PAGE NO.	PARA-GRAPH	LINE NO. *	FIGURE NO.	TABLE NO.	RECOMMENDED CHANGES AND REASON <i>(Provide exact wording of recommended changes, if possible).</i>	
	0036 00-2				1	<i>In table 1, Sewing Machine Code Symbols, the second sewing machine code symbol should be MD ZZ not MD 22.</i> <i>Change the manual to show Sewing Machine, Industrial: Zig-Zag; 308 stitch; medium-duty; NSN 3530-01-181-1421 as a MD ZZ code symbol.</i>	
<small>*Reference to line numbers within the paragraph or subparagraph.</small>							
TYPED NAME, GRADE OR TITLE Jane Doe, PFC				TELEPHONE EXCHANGE/AUTOVON, PLUS EXTENSION 508-233-4141		SIGNATURE Jane Doe <i>Jane Doe</i>	

TO: (Forward direct to addressee listed in publication) COMMANDER U.S. ARMY TANK-AUTOMOTIVE AND ARMAMENT COMMAND ATTN: AMSTA-LC-CECT 15 KANSAS STREET NATICK, MA 01760-5052	FROM: (Activity and location) (Include ZIP Code) <i>PFC Jane Doe</i> <i>CO A 3rd Engineer BR</i> <i>Ft. Leonardwood, MO 63108</i>	DATE <i>21 October 2003</i>
---	--	---------------------------------------

PART II – REPAIR PARTS AND SPECIAL TOOL LISTS AND SUPPLY CATALOGS/SUPPLY MANUALS

PUBLICATION NUMBER TM 10-1670-296-23&P	DATE 30 October 2002	TITLE Unit Manual for Ancillary Equipment for Low Velocity Air Drop Systems
--	--------------------------------	---

PAGE NO.	COLM NO.	LINE NO.	NATIONAL STOCK NUMBER	REFERENCE NO.	FIGURE NO.	ITEM NO.	TOTAL NO. OF MAJOR ITEMS SUPPORTED	RECOMMENDED ACTION
0066 00-1					4			<i>Callout 16 in figure 4 is pointed to a <u>D-Ring</u>. In the Repair Parts List key for figure 4, item 16 is called a <u>Snap Hook</u>. Please correct one or the other.</i>

PART III – REMARKS (Any general remarks or recommendations, or suggestions for improvement of publications and blank forms. Additional blank sheets may be used if more space is needed.)

--	--	--

TYPED NAME, GRADE OR TITLE	TELEPHONE EXCHANGE/AUTOVON, PLUS EXTENSION	SIGNATURE
----------------------------	--	-----------

<p align="center">RECOMMENDED CHANGES TO PUBLICATIONS AND BLANK FORMS</p> <p>For use of this form, see AR 25-30; the proponent agency is ODISC4.</p>						Use Part II (reverse) for Repair Parts and Special Tool Lists (RPSTL) and Supply Catalogs/Supply Manuals (SC/SM).	DATE
TO: (Forward to proponent of publication or form) (Include ZIP Code) COMMANDER U.S. ARMY TANK-AUTOMOTIVE AND ARMAMENT COMMAND ATTN: AMSTA-LC-CECT 15 KANSAS STREET NATICK, MA 01760-5052						FROM: (Activity and location) (Include ZIP Code)	
PART I – ALL PUBLICATIONS (EXCEPT RPSTL AND SC/SM) AND BLANK FORMS							
PUBLICATION/FORM NUMBER TM 9-4110-246-14				DATE 1 July 1992	TITLE Operator's, Unit, Direct Support and General Support Maintenance Manual for Refrigerator, Prefabricated		
ITEM NO.	PAGE NO.	PARA-GRAPH	LINE NO. *	FIGURE NO.	TABLE NO.	RECOMMENDED CHANGES AND REASON <i>(Provide exact wording of recommended changes, if possible).</i>	
<i>*Reference to line numbers within the paragraph or subparagraph.</i>							
TYPED NAME, GRADE OR TITLE				TELEPHONE EXCHANGE/AUTOVON, PLUS EXTENSION		SIGNATURE	

TO: <i>(Forward direct to addressee listed in publication)</i> COMMANDER U.S. ARMY TANK-AUTOMOTIVE AND ARMAMENT COMMAND ATTN: AMSTA-LC-CECT 15 KANSAS STREET NATICK, MA 01760-5052	FROM: <i>(Activity and location) (Include ZIP Code)</i>	DATE
--	--	-------------

PART II – REPAIR PARTS AND SPECIAL TOOL LISTS AND SUPPLY CATALOGS/SUPPLY MANUALS

PUBLICATION NUMBER TM 9-4110-246-14	DATE 1 July 1992	TITLE Operator's, Unit, Direct Support and General Support Maintenance Manual for Refrigerator, Prefabricated
--	---------------------	---

PAGE NO.	COLM NO.	LINE NO.	NATIONAL STOCK NUMBER	REFERENCE NO.	FIGURE NO.	ITEM NO.	TOTAL NO. OF MAJOR ITEMS SUPPORTED	RECOMMENDED ACTION

PART III – REMARKS *(Any general remarks or recommendations, or suggestions for improvement of publications and blank forms. Additional blank sheets may be used if more space is needed.)*

TYPED NAME, GRADE OR TITLE	TELEPHONE EXCHANGE/AUTOVON, PLUS EXTENSION	SIGNATURE
----------------------------	--	-----------

<p align="center">RECOMMENDED CHANGES TO PUBLICATIONS AND BLANK FORMS</p> <p>For use of this form, see AR 25-30; the proponent agency is ODISC4.</p>						Use Part II (reverse) for Repair Parts and Special Tool Lists (RPSTL) and Supply Catalogs/Supply Manuals (SC/SM).	DATE
TO: (Forward to proponent of publication or form) (Include ZIP Code) COMMANDER U.S. ARMY TANK-AUTOMOTIVE AND ARMAMENT COMMAND ATTN: AMSTA-LC-CECT 15 KANSAS STREET NATICK, MA 01760-5052						FROM: (Activity and location) (Include ZIP Code)	
PART I – ALL PUBLICATIONS (EXCEPT RPSTL AND SC/SM) AND BLANK FORMS							
PUBLICATION/FORM NUMBER TM 9-4110-246-14				DATE 1 July 1992		TITLE Operator's, Unit, Direct Support and General Support Maintenance Manual for Refrigerator, Prefabricated	
ITEM NO.	PAGE NO.	PARA-GRAPH	LINE NO. *	FIGURE NO.	TABLE NO.	RECOMMENDED CHANGES AND REASON <i>(Provide exact wording of recommended changes, if possible).</i>	
*Reference to line numbers within the paragraph or subparagraph.							
TYPED NAME, GRADE OR TITLE				TELEPHONE EXCHANGE/AUTOVON, PLUS EXTENSION		SIGNATURE	

TO: <i>(Forward direct to addressee listed in publication)</i> COMMANDER U.S. ARMY TANK-AUTOMOTIVE AND ARMAMENT COMMAND ATTN: AMSTA-LC-CECT 15 KANSAS STREET NATICK, MA 01760-5052	FROM: <i>(Activity and location) (Include ZIP Code)</i>	DATE
--	--	-------------

PART II – REPAIR PARTS AND SPECIAL TOOL LISTS AND SUPPLY CATALOGS/SUPPLY MANUALS

PUBLICATION NUMBER TM 9-4110-246-14	DATE 1 July 1992	TITLE Operator's, Unit, Direct Support and General Support Maintenance Manual for Refrigerator, Prefabricated
--	---------------------	---

PAGE NO.	COLM NO.	LINE NO.	NATIONAL STOCK NUMBER	REFERENCE NO.	FIGURE NO.	ITEM NO.	TOTAL NO. OF MAJOR ITEMS SUPPORTED	RECOMMENDED ACTION

PART III – REMARKS *(Any general remarks or recommendations, or suggestions for improvement of publications and blank forms. Additional blank sheets may be used if more space is needed.)*

TYPED NAME, GRADE OR TITLE	TELEPHONE EXCHANGE/AUTOVON, PLUS EXTENSION	SIGNATURE
----------------------------	--	-----------

The Metric System and Equivalents

Linear Measure

1 centimeter = 10 millimeters = .39 inch
 1 decimeter = 10 centimeters = 3.94 inches
 1 meter = 10 decimeters = 39.37 inches
 1 dekameter = 10 meters = 32.8 feet
 1 hectometer = 10 dekameters = 328.08 feet
 1 kilometer = 10 hectometers = 3,280.8 feet

Weights

1 centigram = 10 milligrams = .15 grain
 1 decigram = 10 centigrams = 1.54 grains
 1 gram = 10 decigrams = .035 ounce
 1 dekagram = 10 grams = .35 ounce
 1 hectogram = 10 dekagrams = 3.52 ounces
 1 kilogram = 10 hectograms = 2.2 pounds
 1 quintal = 100 kilograms = 220.46 pounds
 1 metric ton = 10 quintals = 1.1 short tons

Liquid Measure

1 centiliter = 10 milliliters = .34 fl. ounce
 1 deciliter = 10 centiliters = 3.38 fl. ounces
 1 liter = 10 deciliters = 33.81 fl. ounces
 1 dekaliter = 10 liters = 2.64 gallons
 1 hectoliter = 10 dekaliters = 26.42 gallons
 1 kiloliter = 10 hectoliters = 264.18 gallons

Square Measure

1 sq. centimeter = 100 sq. millimeters = .155 sq. inch
 1 sq. decimeter = 100 sq. centimeters = 15.5 sq. inches
 1 sq. meter (centare) = 100 sq. decimeters = 10.76 sq. feet
 1 sq. dekameter (are) = 100 sq. meters = 1,076.4 sq. feet
 1 sq. hectometer (hectare) = 100 sq. dekameters = 2.47 acres
 1 sq. kilometer = 100 sq. hectometers = .386 sq. mile

Cubic Measure

1 cu. centimeter = 1000 cu. millimeters = .06 cu. inch
 1 cu. decimeter = 1000 cu. centimeters = 61.02 cu. inches
 1 cu. meter = 1000 cu. decimeters = 35.31 feet

Approximate Conversion Factors

<i>To change</i>	<i>To</i>	<i>Multiply by</i>	<i>To change</i>	<i>To</i>	<i>Multiply by</i>
inches	centimeters	2.540	ounce-inches	newton-meters	.007062
feet	meters	.305	centimeters	inches	.394
yards	meters	.914	meters	feet	3.280
miles	kilometers	1.609	meters	yards	1.094
square inches	square centimeters	6.451	kilometers	miles	.621
square feet	square meters	.093	square centimeters	square inches	.155
square yards	square meters	.836	square meters	square feet	10.764
square miles	square kilometers	2.590	square meters	square yards	1.196
acres	square hectometers	.405	square kilometers	square miles	.386
cubic feet	cubic meters	.028	square hectometers	acres	2.471
cubic yards	cubic meters	.765	cubic meters	cubic feet	35.315
fluid ounces	milliliters	29.573	cubic meters	cubic yards	1.308
pints	liters	.473	milliliters	fluid ounces	.034
quarts	liters	.946	liters	pints	2.113
gallons	liters	3.785	liters	quarts	1.057
ounces	grams	28.349	liters	gallons	.264
pounds	kilograms	.454	grams	ounces	.035
short tons	metric tons	.907	kilograms	pounds	2.205
pound-feet	newton-meters	1.356	metric tons	short tons	1.102
pound-inches	newton-meters	.11296			

Temperature (Exact)

 °F Fahrenheit temperature 5/9 (after subtracting 32)

Celsius temperature °C

PIN: 069965-000